

Project No. 609687
FP7-ENERGY-2013-IRP

ELECTRA

European Liaison on Electricity Committed Towards long-term Research Activities for Smart Grids

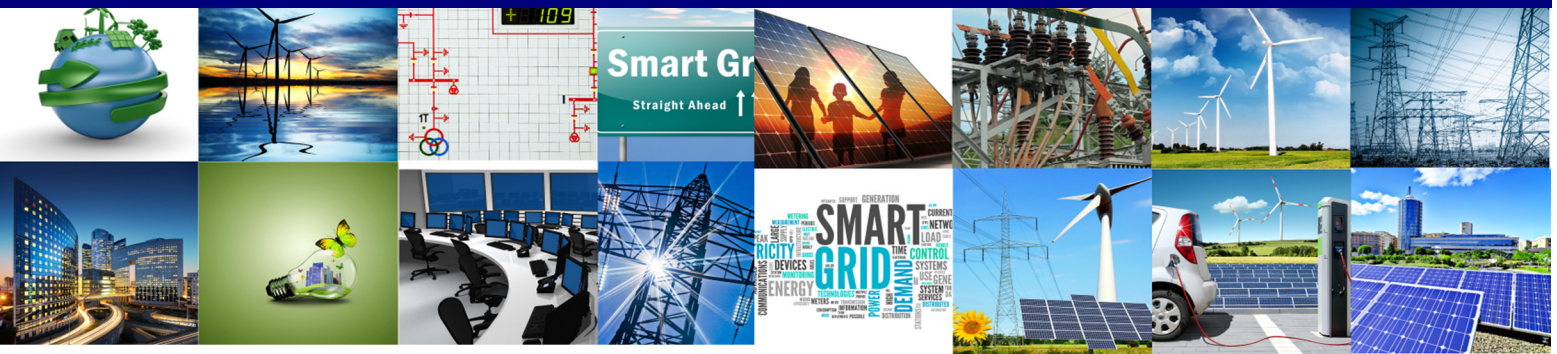

WP 5

Increased Observability

Deliverable 5.2

Functional description of the monitoring and observability detailed concepts for the Distributed Local Control Schemes

22/12/2015

ID&Title	D5.2 Functional description of the monitoring and observability detailed concepts for the Distributed Local Control Schemes <Intermediate version>		Number of pages:	60
Short description (Max. 50 words):				
This Intermediate Version of the D5.2 document outlines a methodology specifically created for developing and testing observables for the Web-of-Cells (WoC) concept.				
Version	Date	Modification's nature		
V0.01	30/06/2015	First Draft		
V0.02	07/07/2015	Revised Draft		
V0.03	17/07/2015	Final Draft		
V1.00	18/10/2015	Under review		
V1.01	20/12/2015	Revised - under review		
V2.00	22/12/2015	Released		
Accessibility				
X PU, Public				
<input type="checkbox"/> PP, Restricted to other program participants (including the Commission Services)				
<input type="checkbox"/> RE, Restricted to other a group specified by the consortium (including the Commission Services)				
<input type="checkbox"/> CO, Confidential, only for members of the consortium (including the Commission Services)				
If restricted, please specify here the group:				
Owner / Main responsible:				
Task 5.2 Leader:		Klaas Visscher (TNO)	20/12/2015	
Reviewed by:				
(WP5 Leader: (Technical Project Coordinator): (Project Coordinator):		Andrei Morch (SINTEF) Helfried Brunner (AIT) Luciano Martini (RSE)	20/12/2015	
Final Approval by:				
ELECTRA Technical Committee TOQA appointed Reviewer:		Seppo Hänninen (VTT) Mihai Calin (DERLAB)	22/12/2015	

Authors

Name	Last Name	Organization	Country
Klaas	Visscher (Lead Editor)	TNO	The Netherlands
Andrei	Morch	SINTEF	Norway
Sigurd Hofsmo	Jakobsen	SINTEF	Norway
Håkon	Marthinsen	SINTEF	Norway
Evangelos	Rikos	CRES	Greece
Julia	Merino Fernández	TECNALIA	Spain
Emilio	Rodríguez	TECNALIA	Spain
Berend	Evenblij	TNO	The Netherlands
Thomas	Strasser	AIT	Austria
Roman	Schwalbe	AIT	Austria
Eric	Nens	LAB	Belgium
Martin	Legry	LAB	Belgium

Copyright

@ Copyright 2013-2016 The ELECTRA Consortium

Consisting of:

Coordinator	
Ricerca Sul Sistema Energetico – (RSE)	Italy
Participants	
Austrian Institute of Technology GmbH - (AIT)	Austria
Vlaamse Instelling Voor Technologisch Onderzoek N.V. - (VITO)	Belgium
Belgisch Laboratorium Van De Elektriciteitsindustrie - (LABORELEC)	Belgium
Danmarks Tekniske Universitet - (DTU)	Denmark
Teknologian Tutkimuskeskus - (VTT)	Finland
Commissariat A L'Energie Atomique Et Aux Energies Alternatives - (CEA)	France
Fraunhofer-Gesellschaft Zur Förderung Der Angewandten Forschung E.V – (IWES)	Germany
Centre For Renewable Energy Sources And Saving - (CRESES)	Greece
Agenzia Nazionale per Le Nuove Tecnologie, L'Energia E Lo Sviluppo Economico Sostenibile - (ENEA)	Italy
Fizikālas Enerģētikas Institūts - (IPE)	Latvia
SINTEF Energi AS - (SINTEF)	Norway
Instytut Energetyki - (IEN)	Poland
Instituto De Engenharia De Sistemas E Computadores Do Porto - (INESC_P)	Portugal
Fundacion Tecnalia Research & Innovation - (TECNALIA)	Spain
Joint Research Centre European Commission - (JRC)	Belgium
Nederlandse Organisatie Voor Toegepast Natuurwetenschappelijk Onderzoek – (TNO)	Netherlands
Türkiye Bilimsel Ve Teknolojik Arastirma Kurumu - (TUBITAK)	Turkey
University Of Strathclyde - (USTRATH)	UK
European Distributed Energy Resources Laboratories (DERLab)	Germany
Institute for Information Technology at University of Oldenburg (OFFIS)	Germany

This document may not be copied, reproduced, or modified in whole or in part for any purpose without written permission from the ELECTRA Consortium. In addition to such written permission to copy, reproduce, or modify this document in whole or part, an acknowledgment of the authors of the document and all applicable portions of the copyright notice must be clearly referenced.

All rights reserved.

This document may change without notice.

Executive summary

This Intermediate Version of the D5.2 document outlines the methodology adopted to define and test observables for the new power system control concept proposed, the so-called Web-of-Cells (WoC) concept. Starting from the future power system development (2035+) with a very high share of non-programmable RES mainly connected to the medium and low voltage power grid, it is straightforward to propose a rethinking of the current power system control strategy approach. In particular it is recommendable to overtake the conventional control schemes of the power system, based on voltage and frequency controls traditionally supplied by the largest power plants directly connected to the transmission system, and to replace those schemes with new ones, in order to take into account new distributed devices in operation, new ancillary resource requirements and new ancillary services suppliers. This implies a complicated process in terms of the definition of new control strategies and new technical requirements. In ELECTRA, in particular, instead of conventional frequency controls, more general balance types of control have been introduced, which, although including control of frequency itself, primarily involve control of active power exchanges. As for voltage controls, a two-stage structure, therefore simpler than the three-stage conventional one, is proposed. The adopted control approach comprises a generic physical description of the control challenge (balance control or voltage control), which is both technology independent and voltage level independent. So the generic definitions "balance control" and "voltage control" can be applied to all power system technologies, such as AC, DC, Superconducting, and to all voltage levels HV, MV, LV, et cetera. The envisaged approach requires the introduction of several new terms and definitions, which have been proposed in cooperation with mainly WP6 and also WP4. Some of these have been further developed from the previous Tasks, such as Control Time Scales (CTS), while the others are new, such as Control Topology Levels (CTL).

A selection of not regularly used Observables and Observable Algorithms (to compute observables from physical measurements) is made that serve the main Use Cases defined in ELECTRA Deliverable D3.1 "*Specification of Smart Grids high level functional architecture for frequency and voltage control*". These observable algorithms are to be further defined and tested within this Task 5.2 activity.

Preparing to the succeeding part of the Task 5.2 with implementations and testing, a specific part of work was dedicated to the further development of the Single Reference Power System (SRPS) started in Task 5.1. Among the major novelties is a demonstration of the SRPS for a simple test network.

The results indicate that the WoC concept together with the above mentioned methodology built on top of the well-known Use Case methodology are viable tools for determining observables for an electric power system supporting future energy systems.

Terminologies

Definitions

The ELECTRA IRP project has a commonly coordinated strategy related to the use of terms and definitions within the project. In WP4 “Interoperable Systems” an ELECTRA Glossary has been created, which collects and validates specific terms and definitions. The ELECTRA Glossary is available for the projects’ participants in the file repository at www.electrairp.eu and is not included in the present document.

The ELECTRA Glossary is intended to be continuously updated during the project. In particular several new terms and definitions have been introduced or developed in WP5 “*Increased Observability*” for the scope of the ELECTRA project, or have a meaning different from the commonly used one. All these terms and definitions will be included in the Glossary.

The Table below shows a selection of the key definitions. Some of these were initially introduced in the preceding Task 5.1 and modified later on.

Table 1: Key definitions in the ELECTRA project

Term	Definition
Control Triple	A set consisting of {Control Aim, Observable, System Input Signal}, which is the basis of a control loop.
Control Quadruple	A Control Triple, extended with the element “Observable Algorithm”.
Control Aim	A concise statement describing the control purpose of a control loop.
Observable	A uniquely valued function of a number of measurable quantities in a physical system. An observable can either be a scalar or vector (“State Vector”) that is calculated from measured (observed) values in the present or past.
Transition Time	Time for system response or system control loops to complete the transition from a stationary system state to the next stationary state, after a switching event occurs within a power system.
Control Time Scale	A characteristic Transition Time at which a control loop operates. In this document the following Control Time Scales (CTS) are used: <ul style="list-style-type: none"> • CTS_0: System response • CTS_1: Primary Level • CTS_2: Secondary Level • CTS_3: Tertiary Level
System Input Signal	A (scalar or vector) signal that is input to the power system, in order to change the value of an observable.
Observable algorithm	A detailed description of (or reference to) a specific set of operations that convert measurable values into an observable.
Control Topology Level	A characteristic Topology Level at which a control loop operates. Here the following Control Topology Levels (CTLs) are used: <ul style="list-style-type: none"> • CTL_0: Physical (single) Device Level • CTL_1: Flexible (aggregate) Resource Level • CTL_2: Cell level • CTL_3: Inter-cell level (For a more detailed definition of the Control Topology Levels see, [9] chapter 21.5. “Working procedure for selecting control functions for Use

Term	Definition
	Cases")
Balance Control	Control loops that serve to keep the power balance between generation and loads.
Voltage Control	Control loops that ensure that voltage at each node keeps within operational limits, in a stable, secure and reliable way. Voltage control includes the needed control of power flow in all cables and lines in the network, with methods depending on the used power system technologies (AC, DC).
<p><i>N.B: The definitions of "Balance Control" & "Voltage Control" comprise a generic physical description of the control challenge, which is both technology independent and voltage level independent. So these generic definitions can be applied to all power system technologies. such as AC, DC, Super conduction, and to all voltage levels HV, MV, LV, et cetera.</i></p>	
Cell	A group of interconnected loads, concentrated generation plants and/or distributed energy resources, and storage units within well-defined grid boundaries corresponding to a physical portion of the grid and corresponding to a confined geographical area.

Abbreviations

ALF	Accuracy Limit Factor
AVR	Automatic Voltage Regulator
BRC	Balance Restoration Control
BRP	Balance Responsible Party
BSC	Balance Steering Control
CTL	Control Topology Level
CTS	Control Time Scale
CVD	Capacitive Voltage Divider
CVT	Capacitor Voltage Transformers
D	Deliverable
DER	Distributed Energy Resources
DFT	Discrete Fourier Transform
DSO	Distribution System Operator
ENOB	Effective Number Of Bits
ESS	Energy Storage System
FCC	Frequency Containment Control
GPS	Global Positioning System
IEC	International Electrotechnical Committee
IFSC	Institute Of Santa Catarina

IRP	Integrated Research Program
IRPC	Inertia Response Power Control
LSB	Least Significant Bit
MS	Milestones
NPFC	Network Power Frequency Characteristic
OPF	Optimal Power Flow
PCC	Point of Common Coupling
PLC	Power Line Carrier
PMU	Phasor Measurement Unit
PPVC	Post-Primary Voltage Control
PSS	Power System Stabilizer
PVC	Primary Voltage Control
R	Internal Report
RES	Renewable Energy Sources
RMS	Root-Mean-Square
ROCOF	Rate-Of-Change-Of-Frequency
SCADA	Supervisory Control And Data Acquisition
SE	State Estimator
SF	Safety Factor
SMES	Superconducting Magnetic Energy Storage Systems
SNR	Signal-to-Noise Ratio
SOC	State Of Charge (Of Energy Storage System)
SRPS	Single Reference Power System
SVC	Static Var Compensator
TSO	Transmission System Operator
UC	Use Case
WOC	Web-of-Cells

Table of contents

1	Introduction.....	12
1.1	WP5 “Increased Observability”	12
1.2	Relation to other WPs	13
1.3	Assumptions and limitations of the study.....	14
1.4	ELECTRA approach to power system control: main definitions	15
1.4.1	Web-of-Cells concept - solving local problems locally	15
1.4.2	Balance and Voltage Control.....	16
1.4.3	Use Cases	17
1.5	Deliverable contents.....	18
2	Methodology.....	19
2.1	General Methodology.....	19
2.1.1	Working procedure for selecting observables and their algorithms	19
2.1.2	Black Box control loop interface to other WPs.....	20
2.1.3	Control relations in the Web-of-Cells power system	21
2.2	Methodology - Balance and Voltage Control	23
2.2.1	Methodology - Sub-Task 5.2.3.Basic control loop simulation, based on chosen Control Triples.....	23
2.2.2	Methodology - Sub-Task 5.2.4. Hardware test.....	26
2.3	Methodology - Balance Control	27
2.3.1	Used Methodology	27
2.3.2	Methodology - Sub-Task 5.2.1.Identify needed Control Triples from Use Cases ...	35
2.3.3	Methodology - Sub-Task 5.2.2.Determination methods for specific observables	36
2.3.4	Methodology - Sub-Task 5.2.3.Basic control loop simulation, based on chosen Control Triples.....	40
2.3.5	Methodology - Sub-Task 5.2.4.Hardware test (lab table).....	41
2.4	Methodology - Voltage Control	41
2.4.1	Used Methodology	41
2.4.2	Methodology - Sub-Task 5.2.1.Identify needed Control Triples from Use Cases	45
2.4.3	Methodology - Sub-Task 5.2.2.Determination methods for specific observables	47
2.4.4	Methodology - Sub-Task 5.2.3.Basic control loop simulation, based on chosen Control Triples.....	48
2.4.5	Methodology - Sub-Task 5.2.4.Hardware test (lab table).....	49
3	Selection of Observables for the Main Use Cases.....	50
3.1	Control Triples for Balance Control.....	51

3.2	Control Triples for Voltage Control	52
3.3	Resulting observables and their algorithms for Balance Control.....	53
3.4	Resulting Observables and their algorithms for Voltage Control.....	54
3.5	Selection of Observables for further definition and testing.....	55
4	Conclusions.....	57
5	References.....	58
6	Disclaimer.....	59
Annex: Summary of SRPS candidates		
Annex: General Measurements Chain for the currents and voltages by means of Phasor Measurements Units		

List of figures and tables

Figure 1: Black Box Control System and interfaces between WP4, WP5, WP6, and WP7.....	13
Figure 2: Schematic example of the proposed “Web-of-Cells” architecture. Source: [2].....	16
Figure 3: Working procedure for selecting observables and their algorithms.....	19
Figure 4: General Control Loop with Black Box Functions.....	21
Figure 5: Control relations in the Web-of-Cells power system.....	22
Figure 6: Example grid for SRPS description.....	24
Figure 7: Example grid for SRPS - Black Box Terminal parameters.....	25
Figure 8: Example grid for SRPS - Node connections of black box terminals.....	25
Figure 9: Example grid for SRPS - Nominal powers of black box terminals.....	25
Figure 10: Example grid for SRPS - Nominal voltages of terminals.....	26
Figure 11: Activation timeframe for all four Balance Control schemes.....	29
Figure 12: Example of four interconnected Cells through various operation and Balance Control stages.....	31
Figure 13: Evolution of frequency and tie-line power flow: control aim of combined Inertial, FCC and BRC over time after an incident within the unbalanced Cell.....	32
Figure 14: Evolution of real power and control aim of BSC in both reactive (top diagram) and proactive (bottom diagram) mode.....	34
Figure 15: General block diagram of the measurement chain.....	37
Figure 16: Data acquisition process.....	38
Figure 17: Integration of PMUs in the power systems.....	39
Figure 18: Activation timeframes for voltage control schemes.....	43
Figure 19: Evolution of rms voltage profile and voltage control domain.....	44
Figure 20: Example of four interconnected cells through various operation and Voltage Control stages.....	45
Figure 21: D5.2 Workflow - Observable Selection.....	50
Table 1: Key definitions in the ELECTRA project.....	6
Table 2: Main Use Cases in ELECTRA.....	17
Table 3: Overview of Balance Control Use Cases and corresponding Control Aims.....	28
Table 4: Overview of Voltage Control UCs and corresponding control aims.....	42
Table 5: Main Use Cases in ELECTRA.....	50
Table 6: Control Triples for Balance Control.....	51
Table 7: Control Triples for Voltage Control.....	52
Table 8: Resulting observables and their algorithms for Balance Control.....	53
Table 9: Resulting Observables and their algorithms for Voltage Control.....	54
Table 10: Selection of not regularly used Observables and Observable Algorithms.....	55

1 Introduction

The European Union has defined several ambitious climate and energy targets including the well-known 20-20-20 ones [5] and the 2050 EU Energy Roadmap [20].

Achieving these goals will require a major change from conventional generation (fossil fuelled power plants) to Renewable Energy Sources (RES) on different scales, ranging from large offshore wind farms to small-scale domestic PVs for instance, and feeding into networks on various voltage levels.

Great challenges are anticipated for the secure operation of the future power system (2035+), in connection with the foreseen transition from centralised to decentralised generation. Implementation of novel control strategies will enhance flexibility of the power system enabling it to accommodate a broad spectrum of decentralised and intermittent renewable energy sources in order to provide sustainable and economical supply of electricity. Some descriptions of energy mix future scenarios in Europe which are compatible with this view are provided in [4].

Some of the above mentioned changes can already be noticed in countries like Denmark, where wind power generation already provides more than 35% (39% in 2014 [7]) of annual electricity consumption and more than 90,000 PV units are feeding into networks on different voltage levels. These changes create several challenges for DSOs and TSOs, making it difficult and costly to operate the system in a reliable and secure manner.

1.1 WP5 “Increased Observability”

Safe accommodation of larger and larger amounts of intermittent and distributed generation into the network and reliable operation of the network itself require a gradual evolution of the network structure and in particular improvement of its control, monitoring and observing. Adequate observability of the system operating state is a requirement for a reliable and secure supply of electricity.

Monitoring of the electricity network in the past was limited by the lack of capable ICT technologies, in combination with the fact that operation of the conventional vertical "downfall" power system did not necessarily require excessive monitoring, especially in the distribution network. Development of ICTs and integration of these as a new layer into the electricity network, also known as smart grids, is diminishing the technical limitations and improving the power system observability.

As an input, control strategies for future grid operation will require a whole new class of system observables in order to suffice the required awareness needed, which will be much higher than at present due to the massive presence of decentralized and stochastic power sources.

The main objective of WP5 "Increased Observability" is therefore to develop and implement adequate concepts and methods for sufficiently observing the state of the future power system along the following three axes:

- Pan-European
- Vertically integrated
- Local (Horizontal/ Distributed)

It is foreseen that during the ELECTRA 3rd year activity, the suggested observability schemes will be defined and harmonised among the partners and then implemented in lab platforms

programmable in advanced languages (Matlab, SciLab or similar); the results will be transferred to WP7.

The present report is the intermediate version (M18) of the second deliverable in WP5 (D5.2) and presents the methodology and first results of Task T5.2 "Observables for Distributed Local Control Schemes".

1.2 Relation to other WPs

The text below is in accordance with the similar chapter in Deliverable D6.1, “*Functional specification of the control functions for the control of flexibility across the different control boundaries*”.

In order to develop coordinated control functions in T6.2, the work is based on close collaboration between:

- WP4 - Fully Interoperable Systems
- WP5 - Increased Observability
- WP6 - Control Schemes for the use of flexibility
- WP7 - Integration and Lab Testing for Proof of Concept

To simplify understanding of the roles of different WPs, Figure 1 shows the abstraction of the control system and how different work packages interface with each other and with the individual parts of the control system.

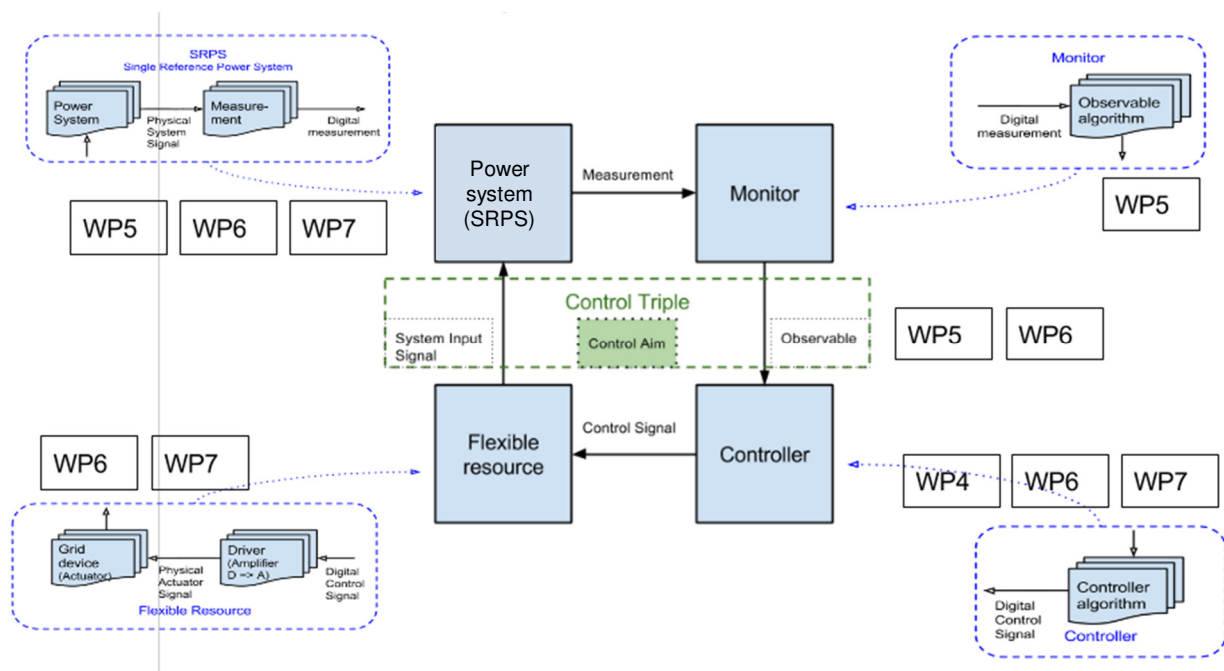

Figure 1: Black Box Control System and interfaces between WP4, WP5, WP6, and WP7.

In this abstraction, the control system consists of four “black boxes”: Power System [3], Monitor, Controller, and Flexible Resource. SRPS stands for “Single Reference Power System”, which is a simple formal way to describe the power system under study and which will be dealt with in details in Chapter 2.

In the core of the control system is the so called Control Triple consisting of Control Aim, Observable, and System Input Signal. The development of control systems for the future power system is based on Use Cases. For a certain Use Case or certain coordinated control action or control aim, it is possible to create a simple picture which consists of the four aforementioned “black box” components describing the control system or control loop. The control function needs real measurements and status information of the grid (see the Power System box), both from the network and its connected (flexible) components. The digitized measurements (voltage, current, temperature measurement etc.) are basic measurement signals, all as a function of time. The Monitor processes the measured signal and gives an Observable which is input to the Controller. The Controller compares the Observable to a certain set point value according to the particular control aim. The Controller supplies the control signal to the Flexible Resources. The Flexible Resources provide the System Input Signal to the Power System; that signal, of course, depends on the Control Signal received from the Controller.

The outer corners of Figure 1 describe how the different WPs considered relate to the control system parts, i.e. to the four black boxes. In particular, the upper right corner of Figure 1 refers to WP5, because the monitored signals are processed to observables which are defined by WP5. WP5 and WP6 make use of Control Triples, as these provide a physical basis for the control loop in the abstraction. In the right lower corner of Figure 1, the Controller is relevant to WP4, WP6, and WP7, because control algorithms need to be developed and tested. Flexible Resources have an interface to WP6 and WP7 in left lower corner of Figure 1, because they may include real grid devices (actuators) and drivers (amplifiers) which change the digitalized control signal to a physical analogue actuator signal. In the left upper corner of Figure 1, the Power System is shown to be comprised of two elements: the power grid and the measurements. The latter change physical measured signals to digitized signals for the Monitor. This interfaces to WP5 with regard to measurements and observables, and to WP6 and WP7 with regard to module and laboratory testing of control loops using a particular grid model.

1.3 Assumptions and limitations of the study

The overall objective of the ELECTRA project is to develop new control solutions for 2035 and beyond. Expectations and scenarios for a future with such a relatively distant time horizon will inevitably contain a substantial amount of uncertainty. Even though the work package has tried to mitigate the overall uncertainty relating to the publically available roadmaps for the near future it is still necessary to make several assumptions in order to handle these future uncertainties. The following main assumptions have been made:

- **Technology and cost limitations are not fully considered.** Considering the rapid development during recent years in technologies such as communications and computation, and the long time horizon that is being considered within the project, the Task decided not to constrain itself to the present technological limitations. Similarly, the present high costs for the most recent and less spread technologies are not considered as an actual limitation, because technological advancement normally leads to significant cost reductions.
- **Potential conflicts between different control schemes are here not considered.** In fact, these conflicts are planned to be addressed more specifically in WP6 "Controllable Flexibility" according to the project's DOW. Therefore the present Task does not omit any control schemes due to potential conflicts between these.

1.4 ELECTRA approach to power system control: main definitions

1.4.1 Web-of-Cells concept - solving local problems locally

In the future grid, a scenario shift is expected from large central synchronous generators at transmission level to smaller, and usually intermittent (such as PV panels, wind turbines, etc.), production units at distribution level, which cannot participate directly in central balancing by the TSO and do not provide inertial response power for instantaneous balancing. Furthermore, coincident non-intermittent loads like EV battery charging stations and heat pumps may cause temporary overloads in LV and MV substations and lines.

One of the key pillars in the ELECTRA vision is that the European 2020 goals are not achievable without radical changes in the existing power system control paradigm. During the course of the project a novel architecture concept for the future power system has been suggested. The “Web-of-Cells” concept was coined, which is described more specifically in Deliverable D3.1 [\[2\]](#) and will be further elaborated in subsequent Tasks in WP4. Following this concept, the future European power grid will be decomposed into a new structure - the Web-of-Cells, where the cells are defined as follows:

- A cell is a group of interconnected loads, concentrated generation plants and/or distributed energy resources, and storage units within well-defined grid boundaries corresponding to a physical portion of the grid and corresponding to a confined geographical area.
- A cell is not a microgrid. In ELECTRA, microgrids are defined as being able to operate in grid-connected as well as “island” mode [\[6\]](#). Being able to operate in island mode is not a requirement of a cell.
- A cell is in 'normal state' when in real-time operation:
 - it is able to follow the scheduled consumption/generation set-point so that the voltage, frequency and power flows are within the operational security limits;
 - it is able to activate sufficient flexible ancillary resources (active and reactive power reserves).
- Cells have adequate monitoring infrastructure installed, as well as local reserves capacity, enabling them to resolve voltage and cell balancing problems locally.

Since the concept of WoC is under development within ELECTRA, the above description refers to the latest agreed definition (see [\[2\]](#)). Modification and clarification of several definitions is pending in the moment of writing. A schematic depiction is given in the next Figure 2.

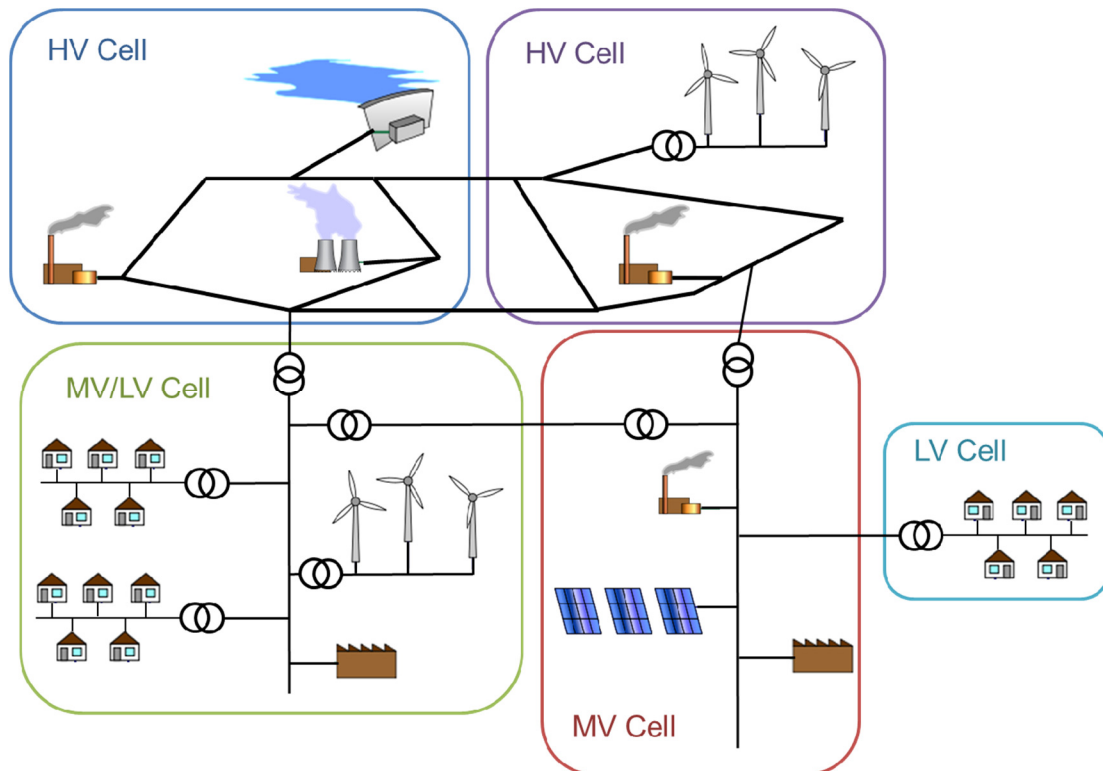

Figure 2: Schematic example of the proposed “Web-of-Cells” architecture. Source: [2]

The ELECTRA vision in brief applies a cell-based control concept for solving local control problems locally, i.e. at cell level, as far as possible. Considering that many partly predictable decentralised resources will dominate the future grid, the cell will serve as a collective system capable of effective distributed control and facilitating efficient use of the decentralised resources.

Even though this cell based approach is expected to be more simple and effective due to its proximity to the source of the problem, compared to the conventional centralised architecture, it has the consequence that global reserves activation optimization is disregarded. Examples of such system-wide optimizations are:

- Economic optimization, by replacing restoration reserves by more cost-effective ones.
- Imbalance netting, system-wide reduction of opposite sign activations.

Disregarding the global optimisation may require coordinative function across cells. This issue is evaluated by the project in the moment of writing.

1.4.2 Balance and Voltage Control

Within the scope of ELECTRA, the terms “Balance Control” and “Voltage Control” are adopted for the two main control functionalities needed:

Balance Control

Control loops that serve to keep the power balance between generation and loads.

Voltage Control

Control loops that ensure that voltage at each node keeps within operational limits, in a stable, secure and reliable way. Voltage control includes the needed control of power flow

in all cables and lines in the network, with methods depending on the used power system technologies (AC, DC).

The definitions of "Balance Control" & "Voltage Control" comprise a generic physical description of the control challenge, which is both technology independent and voltage level independent. So these generic definitions can be applied to all power system technologies, such as AC, DC, Super conduction, and to all voltage levels, HV, MV, LV, et cetera.

Besides, the Balance Control definition aims to be more general than the usual frequency control definition, since it is focused on active power balance, which includes but does not restrict to the control of frequency itself (frequency, of course, can be defined for AC systems only). In other words, correct and stable frequency is an index of power balance (control), but it is not the only variable involved in it.

Voltage Control for AC networks, in particular, mainly involves ensuring the dispatch of the reactive power according to the requirements of the network and of the customers. In this respect, it can be considered as an extension to all voltage levels of the control actions currently taken on reactive power in the very high / high voltage transmission networks. However, on distribution networks, it can also include control actions on active power injection/absorption. Besides, in case of Distributed Generation connected to the MV or LV grid, controlling frequency and voltage may not be independent tasks, but the two controls may have to be coordinated (in fact, acting on active power to control frequency may affect voltage as well). This is a new functionality to be required, for instance, to inverters connecting DG.

1.4.3 Use Cases

Both for balance control and for voltage control, control specifications have been formulated with reference to a set of different objectives to be met in order to ensure power balance, correct power transfer, local and overall system stability and security. These objectives, with the related control actions, are organized into a set of Use Cases. The main Use Cases in the ELECTRA project have been defined in Deliverable D3.1 [2]. They will be dealt with in details in this deliverable; anyway, they are collected together in the next table for convenience.

Table 2: Main Use Cases in ELECTRA

Control Type	Use Case abbreviation	Use Case name	Control aims
Balance Control	B1.IRPC	B1-Inertia Response Power Control	<p>Objective 1: Reacts to frequency changes over time (frequency transient plus dynamic response)</p> <p>Objective 2: Observes and regulates in real time the available amount of inertia within a Cell</p>
	B2.FCC	B2-Frequency Containment Control	<p>Objective 1: Reacts to deviations of the frequency value so as to contain any change and stabilise frequency to a steady-state value</p> <p>Objective 2: Observes and regulates in real time the Network Power Frequency Characteristic (NPFC) for the WoC or NPFC within a Cell</p>
	B3.BRC	B3-Balance Restoration Control	Reacts to absolute frequency deviations in conjunction with the tie line power flow deviations from the scheduled interchanges so as to restore both quantities to their initial values

Control Type	Use Case abbreviation	Use Case name	Control aims
	B4.BSC	B4-Balance Steering Control	Regulates power balance within a Cell (proactively or reactively) in order to replace BRC reserves or mitigate potential imbalances in a cost effective manner
Voltage Control	T1.PVC	T1-Primary Voltage Control	<p>Objective 1: Reacts in case of voltage deviations detected in any nodes of a Cells as a consequence of a severe disturbance</p> <p>Objective 2: observes, monitors and regulates the voltage levels deviations in real-time in the grid nodes within the Cells</p>
	T2.PPVC	T2-Post-Primary Voltage Control	<p>Objective 1: Restores the voltage levels in the grid nodes to the set-point values within in a safe band Simultaneously, it optimizes the reactive power flows in the system.</p> <p>Objective 2: regulates the voltages in the nodes in case of generation-demand imbalances</p>

1.5 Deliverable contents

The present document covers the following activities performed in Task 5.2:

- Clarification of the scope of Local Control schemes
- More specific stepwise definition of the methodological approach for the whole Task
- Identification of control aims, based on a set of Use Cases (UCs) from D3.1 [\[2\]](#)
- Identification of the needed Control Triples, with use and extension of the Control Triples' Survey from D5.1 [\[3\]](#)
- Determination of methods for specific observables

The material in this document is thus organized:

- Task methodology:
 - general methodology (definitions, working procedure, ...);
 - methodological aspects relevant to both Balance and Voltage Control;
 - Balance Control;
 - Voltage Control;
- Selection of observables for the main use cases: separately for balance control and for voltage control:
 - followed methodology;
 - first choices of observables and related simulation results.

The final version of D5.2, scheduled for completion in M33, is intended to update this intermediate version, in particular to:

- Report on basic control loop simulation, including reliability analyses, based on chosen Control Triples
- Implement the suggested observability schemes into modules to be implementable in WP7 "Integration and Lab Testing for Proof of Concept".

2 Methodology

2.1 General Methodology

2.1.1 Working procedure for selecting observables and their algorithms

The procedure followed for selecting observables and their control aims is shown schematically in the next picture:

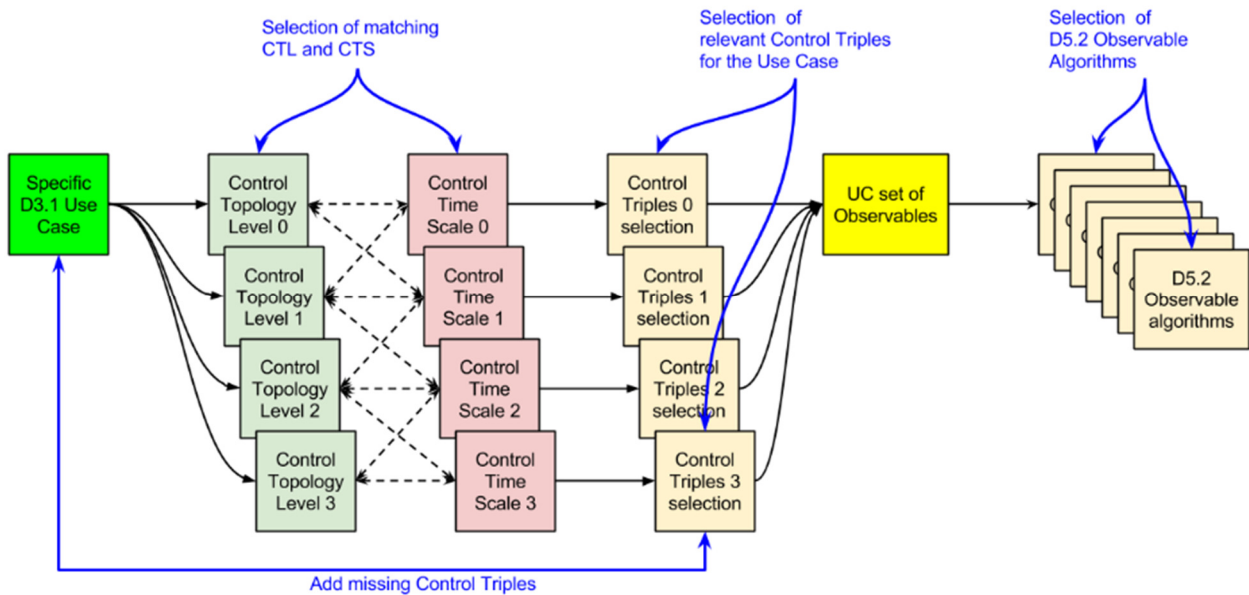

Figure 3: Working procedure for selecting observables and their algorithms.

- The starting point is a specific main Use Case from D3.1 [2]
- For each main Use Case, all possible combinations of Control Topology Levels (CTL) and Control Time Scales (CTS) are listed and kept up-to-date in an online automated spreadsheet, for all WP5 partners to use and update concurrently.
 - This is done in the online spreadsheet "Use Cases-Control Triples" Tab: "UC Sub-Cases" [18]
- For each combination, relevant Control Triples are chosen that can be selected in a cell from an automatically generated drop-down list of previously defined values.
 - These Control Triples are defined in the extension of the D5.1 [3] online spreadsheet [20150119-Observables inventory survey](#).
 - The working procedure of that spreadsheet is described in D5.1. [3]. The first tab of the spreadsheet explains the procedure and contains a link to an online webinar where this is demonstrated (see [10] for the Webinar).
 - Non-existent cases are marked "no case", and automatically the row in question of the spreadsheet turns grey to indicate this to the user.
- From the final list, the set of the selected observables used and their algorithms are filtered out by a pivot table, which is an automated user friendly function.
- Finally, observables are selected that need to be clarified or defined further as they are not commonly used in practice yet. These will be tested in simulation and/or implemented in hardware modules in the remainder of Task 5.2.

2.1.2 Black Box control loop interface to other WPs

Although the Task mainly concerned with the specification of control loops is T6.2 “Development of robust coordination functions for multiple controllers across different control boundaries”, within the frame of T5.2 it is essential that we should define some basic but fully functional control loops that on a later stage will be used as a basis for simulation purposes and validation of the selected control triples.

These control loops are expected to facilitate the clear and common understanding in the consortium of the requirements that led to the selection of the proposed control triples.

In order to have an easy and standardised interface and to facilitate the information transfer to the other WPs in ELECTRA, a Black Box depiction of a control loop interface has been agreed among WP4, WP5 and WP6, as shown in the next figure.

In particular the WP3 “*Scenarios and case studies for future power system operation*” and WP4 “*Fully Interoperable Systems*”, may benefit from the dimensionless signal definitions adopted in the general Black Box depiction in the next figure.

From the perspective of the present Deliverable D5.2, the focus is on the observables and their algorithms, while the description below is given in order to put this into context.

The correct operation of the control loop is based on the Control Triple introduced in deliverable D5.1 [3], and depicted in the center of Figure 4 as {Control Aim, Observable, System Input Signal}.

- The “Monitor” block contains the implementation of an Observable Algorithm, (such an algorithm translates a scalar or vector measured quantity into an observable).
- The “Controller” block contains the implementation of a control algorithm which starts from the observable value and works out an action to be taken by the “Flexible Resource” in order to fulfill the “Control Aim”.
- The “Flexible Resource” represents the needed physical equipment that is able to change the state of the power grid (based on the action order, i.e. the control signal, received from the “Controller”).
- The “Power System (SRPS)” block represents the power grid (model) used.

As for the last item, in order to have a uniform approach towards models, simulations and tests in all WPs, the data necessary to describe the selected power grids and to implement their models are collected under a common format called the “Single Reference Power System” (SRPS), which will be dealt with in Chapter 2.

The signals “Measurement”, “Observable” and “Control signal” are chosen such that they have no physical dimension, and are merely digital signals. All signals can be vectors of values processed simultaneously.

The Monitor processes a Measurement into an Observable, which in turn is processed by a Controller to deliver a Control Signal as an input to a Flexible Resource.

Of course, the physical System Input Signal provided by the Flexible Resource to the power system must be such that it can change the observable value. Otherwise one may end up with a broken control loop that cannot meet its Control Aim.

The Flexible Resource and its physical “System Input Signal” to the “Single Reference Power System” may only appear at the lowest level of a cascaded control where the grid is directly

controlled. At the top level the Control Signal is a direct input to the SRPS, which already contains lower level controls that take the Control Signal as an input.

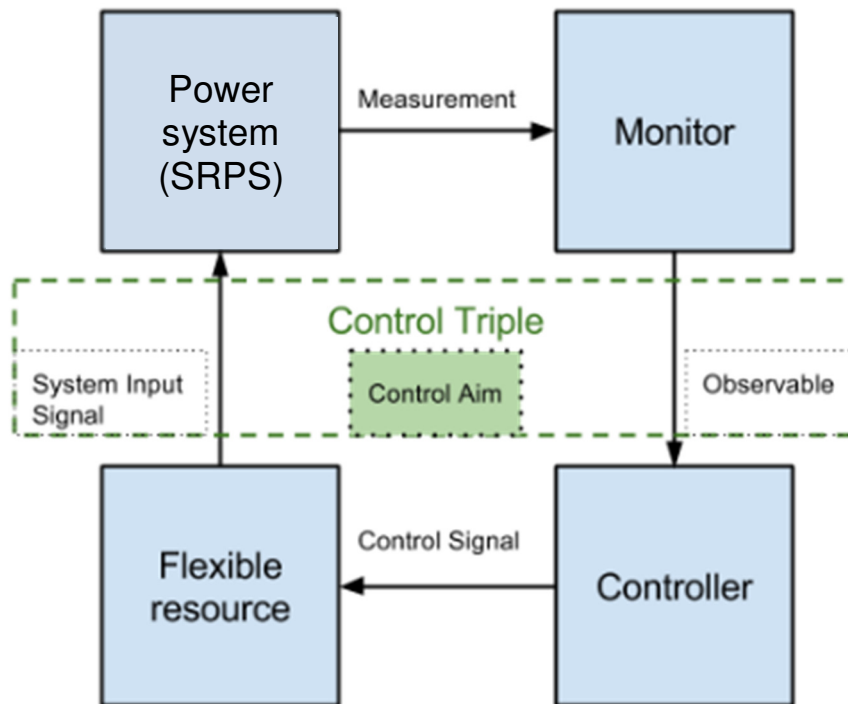

Figure 4: General Control Loop with Black Box Functions.

2.1.3 Control relations in the Web-of-Cells power system

In the next Figure, a partial view is shown of the Control relations in the WoC power system.

At the top we have an Energy Market, which hands out set-points for e.g. cell tie-line power (see the BRC use case) and cell inertia (see the IRPC use case), that lie within Secure Operation Intervals. This is done once per market time interval, e.g. every 15 minutes.

The Power System is monitored in order for an Emergency Control to take necessary actions, in order to prevent blackouts, when the Power System goes into alert condition.

In case of an emergency, the central set-points for the secure Operation Intervals are dictated directly by the Emergency Control, thereby overriding the Energy Market. As soon as normal operation is restored, the control is handed back to the Energy Market again.

The Power System consists of Cells that each have a Cell Monitoring system, which serves both the Cell Control and the Power System Monitoring. The Power System Monitoring is an overall fast Monitoring function that in case of major system events or disruptions can serve Emergency Control in the Web-of-Cells in order to restore normal operation.

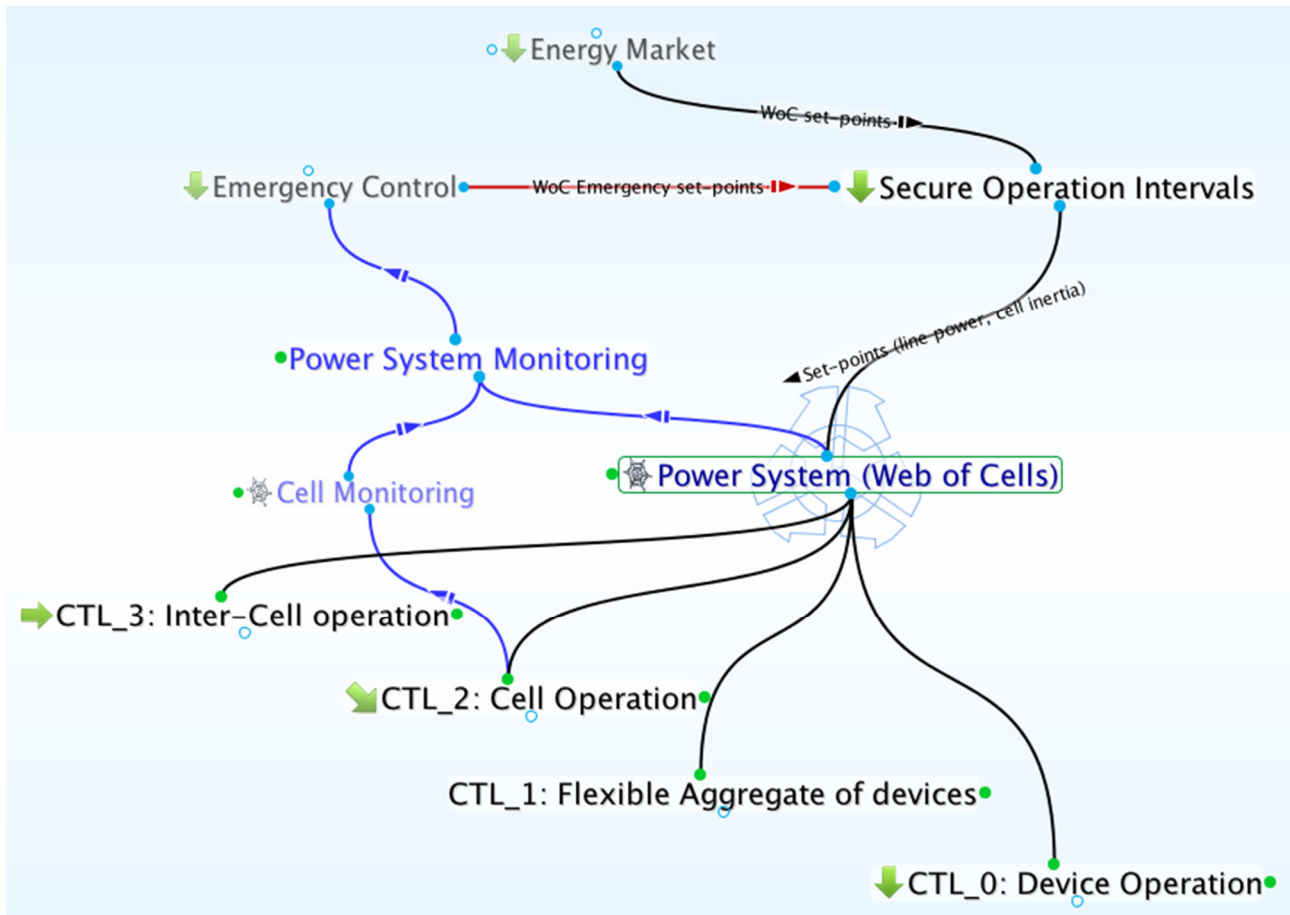

Figure 5: Control relations in the Web-of-Cells power system

Cells are controlled autonomously by Control Functions comprising four Control Topology Levels:

- CTL0: single physical device level
- CTL1: aggregated flexible resource level
- CTL2: cell level
- CTL3: inter-cell level

In general this implies that controls at different CTLs form Cascaded Control schemes, where a control loop at a certain CTL gives the setpoint for the control loop at a lower CTL.

A Control Topology Level operates in a certain Control Time Scale (not shown in the Figure), which depends on the specific Control Function it serves:

- ❖ CTS0: system response (5 s)
- ❖ CTS1: primary level (30 s)
- ❖ CTS2: secondary level (120 s)
- ❖ CTS3: tertiary level (900 s)

These “Control Time Scales” have been defined earlier in [3] D5.1, Chapter “4.4.3 Control Levels”, under the name “Control Levels”. In the present Deliverable, the name has been adapted in order not to get confused with the notion “Control Topology Levels”.

A control scheme at a certain Control Time Scale is defined by a Control Triple. This is a set consisting of {Control Aim, Observable, System Input Signal}, which is the basis of a control loop.

2.2 Methodology - Balance and Voltage Control

2.2.1 Methodology - Sub-Task 5.2.3. Basic control loop simulation, based on chosen Control Triples

2.2.1.1 Choice of simulation software

A power system simulation tool is intended to model the behaviour of different grids with different characteristics, topologies or voltage levels. A particular software package usually comprises several types of elements to build those network models, such as lines, transformers, electrical machines, loads, distributed energy resources (DERs), etc., but it also provides the environment for the definition of user-written models according to some compatible programming language.

The needs of every client depending on his/her business are very different. Due to this, it is not simple to establish a comparison between diverse commercial software, since any of them was designed with different purposes. The selection and the employment of one software is based on multiple factors related to the calculation capabilities, the simplicity of use, the number and types of available models or the friendliness of the interface layout.

A well-known open issue about (power system) simulation software tools is data portability between different simulation platforms. This is because a common exchange data format has not been adopted. This issue is also something to be overcome in the ELECTRA project in order to allow the transference of the results between different WPs.

With the purpose of ensuring the interoperability, a survey has been conducted in order to know about the simulation software capabilities of the partners involved in ELECTRA, and to get an idea about the potential power simulation tools available to be used within the project. Results are compiled in section 3.1.1.1.

2.2.1.2 Methodology - Choice of SRPS

As it was explained in D5.1 [3], the Single Reference Power System (SRPS) is a concept currently under development in ELECTRA and suitable for efficient power system modelling. The SRPS tries to avoid contradicting information in reporting formats and software implementations (incompatible translations between different software implementations of the same physical power system). A set of common definitions and rules for power system description (specifically for the Web-of-Cells control architecture) will be established to enable effective partner cooperation and avoid redundancies and ambiguities.

The SRPS will serve to build comparable simulation models of a certain power system in different simulation languages. The SRPS will only be made once for a certain power system model, and will facilitate the implementation in any specific software used by each partner and the results comparison between them.

For the proper choice of the SRPS an analysis of present test grid models is paramount. Therefore, a second survey has been distributed among the partners to collect examples of grid models developed by private or public institutions (in the framework of other research projects) known by the ELECTRA consortium. Information about commonly used grid models (here called "test grids") repositories from significant institutions was also included.

From all the collected information, a summary table was done to provide an easy view. The main characteristics of the analysed power system models include:

- Data privacy (public, private, restricted)

- Number of nodes
- Voltage levels (LV/MV/HV)
- Type of studies that can be accomplished with the available data (steady-state studies and/or transient regime studies)
- Availability of distributed energy resources models in the grids and their type (Wind, PV, Storage, EV...)
- Data format

A total amount of 14 single test grids and 5 repositories were considered as containing valuable information for the future construction of the ELECTRA SRPS. From the bulk data received, some test grids or repositories were discarded from the outset: the data privacy precluded its employment within the project, they could not be converted to a common SRPS format or there was a lack of essential information in that test grid to be used according to the ELECTRA goals.

In the chapter [10. Annex: Summary of SRPS candidates](#) the main characteristics about the single test grids or repositories assembled from the survey are summarized and presented by using a common template.

2.2.1.3 Define small test grid in SRPS

In ELECTRA the simulation work has been distributed in the following way: basic control loops for balance and Voltage Control will be modelled and simulated in WP5 “Increased Observability” and more complex control systems will be developed in WP6 “Control schemes for the use of flexibility” for controller design and control conflict analysis.

Within the WP5 scope, a small test grid and its description as an SRPS is presented below as an example (just for illustrative purpose of the concept). The selection of the final SRPSs to be used for the different control Use Cases, at different levels (from local to pan-European), is ongoing.

The simple network proposed, and shown in Figure 6, is the following: a synchronous machine is connected through an overhead line to a 10kV/400V transformer; on the LV side of the transformer two cables are used for connection to two loads and a PV array.

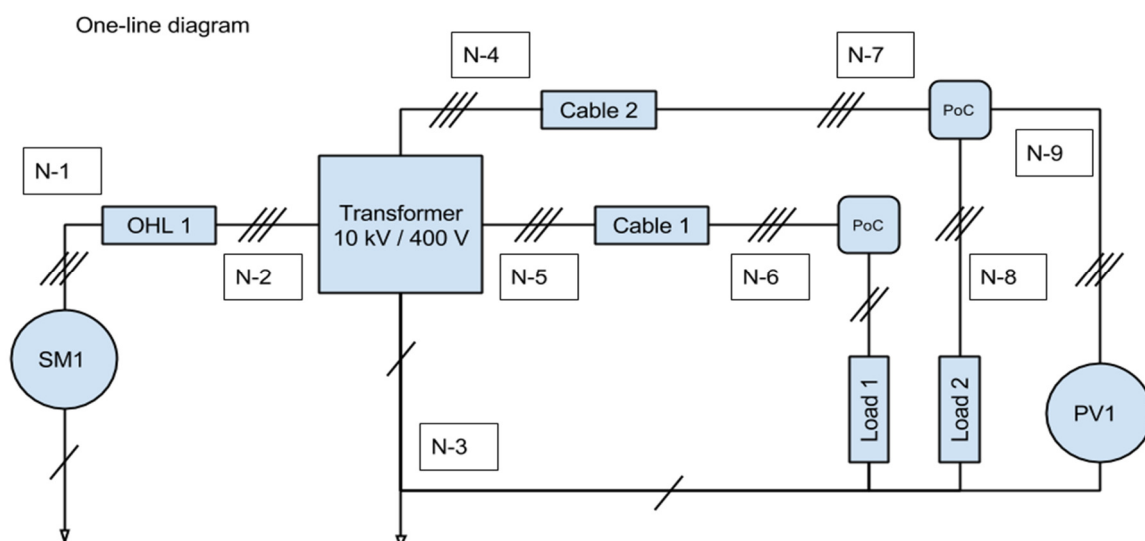

Figure 6: Example grid for SRPS description

Following the SRPS concept, the system above must be described as simply as possible (with the minimum set of parameters for each component), in an unambiguous way, employing a black box approach for the components, and avoiding information that is not interesting for the user.

The information needed for the SRPS description is organised by means of the spreadsheet shown below, where the topology, terminal types and main characteristics of the network elements are considered (just for illustration of the concept).

All numbers in SI base units	Grid Element		Physical description of grid element as black box			
	SRPS Record number	Label	Grid Element Type	Terminal Type-1	Terminal Type-2	Terminal Type-3
1	SM-1	Synchronous Machine	abc	0		
2	OHL-1	Overhead Line	abc	abc		
3	T-1	Transformer	abc	abc	abc	0
4	Cable-1	Cable	abc	abc		
5	Cable-2	Cable	abc	abc		
6	Load-1	Load	abc	0		
7	Load-2	Load	abc	0		
8	PV-1	PV Array	abc	0		

Figure 7: Example grid for SRPS - Black Box Terminal parameters

All numbers in SI base units	Grid Element		Node connections of terminals			
	SRPS Record number	Label	Grid Element Type	Terminal node-1	Terminal node-2	Terminal node-3
1	SM-1	Synchronous Machine	N-1	N-3		
2	OHL-1	Overhead Line	N-1	N-2		
3	T-1	Transformer	N-2	N-4	N-5	N-3
4	Cable-1	Cable	N-5	N-6		
5	Cable-2	Cable	N-4	N-7		
6	Load-1	Load	N-6	N-3		
7	Load-2	Load	N-8	N-3		
8	PV-1	PV Array	N-9	N-3		

Figure 8: Example grid for SRPS - Node connections of black box terminals

All numbers in SI base units	Grid Element		Properties of black box terminals			
	SRPS Record number	Label	Grid Element Type	Nominal power flow of terminals [W]		
			Nominal power [W + j*VAR]-1	Nominal power [W + j*VAR]-1	Nominal power [W + j*VAR]-1	Nominal power [W + j*VAR]-1
1	SM-1	Synchronous Machine	1.00E+05	0.00E+00		
2	OHL-1	Overhead Line	1.00E+04	1.00E+04		
3	T-1	Transformer	1.00E+04	1.00E+04	1.00E+04	0.00E+00
4	Cable-1	Cable	1.00E+04	1.00E+04		
5	Cable-2	Cable	1.00E+04	1.00E+04		
6	Load-1	Load	5.00E+03	0.00E+00		
7	Load-2	Load	5.00E+03	0.00E+00		
8	PV-1	PV Array	3.00E+03	0.00E+00		

Figure 9: Example grid for SRPS - Nominal powers of black box terminals

All numbers in SI base units		Grid Element	Nominal Voltages of terminals [V]			
SRPS Record number	Label	Grid Element Type	Nominal Voltage [V+j*V]-1	Nominal Voltage [V+j*V]-1	Nominal Voltage [V+j*V]-1	Nominal Voltage [V+j*V]-1
1	SM-1	Synchronous Machine	1.00E+04	0.00E+00		
2	OHL-1	Overhead Line	1.00E+04	1.00E+04		
3	T-1	Transformer	1.00E+04	400	400	0
4	Cable-1	Cable	400	4.00E+02		
5	Cable-2	Cable	400	4.00E+02		
6	Load-1	Load	400	0.00E+00		
7	Load-2	Load	400	0.00E+00		
8	PV-1	PV Array	400	0.00E+00		

Figure 10: Example grid for SRPS - Nominal voltages of terminals

2.2.2 Methodology - Sub-Task 5.2.4. Hardware test

From the set of Use Cases (UCs) from D3.1 [2], test cases for the simulations have to be developed. For each test case, the grid, load profiles, control triples, algorithms, component models and all other input parameters have to be defined as well as, if possible, the expected behaviour of the system during simulation and all results that are relevant for the specific UC (input-related errors can be identified more easily this way).

It is expected that most simulations that will be done in the ELECTRA project can be performed in one single power system simulation software tool without the need of interconnection of multiple simulation tools (co-simulation) or coupling with hardware simulation (controller hardware in the loop / C-HIL or power hardware in the loop / P-HIL). Nevertheless, to increase accuracy of models of specific components, or to investigate the behaviour of specific hardware components in detail, co-simulation as well as C-HIL and/or P-HIL simulations will be performed in the lab, if necessary or useful. This integration and validation work is foreseen in WP7.

The final decisions, which parts of the investigated problems / test cases will be tested in the laboratory and implemented in real hardware, will be taken as soon as the complete list of test cases is available. The complexity of the investigated problems, the availability of appropriate testing hardware as well as the available options to create realistic test conditions will be incorporated into this decision process.

2.2.2.1 Generic programmable hardware platform

For demonstration and transfer to WP7 of working observable algorithms these should be either implemented into a programmable unit that can be used in WP7 or the algorithm has to be transferred to a unit already present in the lab. The units, in turn, should be generic enough, to cope with a wide range of possible implementations.

Typical test cases will require power hardware capable of generating arbitrary voltage and current curves, as well as voltage sources that are capable of emulating specific line impedances. Another example will be PV inverters emulating the missing inertia or being capable of other specific frequency control strategies. Furthermore, also hardware tests in laboratories that are capable of modelling LV grids with controllable secondary substation transformers can be possible.

Since the test cases defined may exceed the constraints and parameters of the available testing hardware, a list of hardware platforms with their parameters and constraints that are available within the project consortium will be created. This list will be matched with the test case list to see which laboratory tests are possible. Although the limitations of the laboratory framework should not influence the creation of the test cases, a modification of the test cases to fulfill the hardware constraints can be discussed.

2.3 Methodology - Balance Control

2.3.1 Used Methodology

According to the definition given in deliverable D5.1 [\[3\]](#) a control triple consists of a set of three key-elements:

- Control aim
- Observable
- System input signal

Therefore, the identification of control triples for balance control requires a clear identification of basic control schemes that are needed to realise the control processes. For the refinement of the selected control triples and their harmonisation with the proposed control taxonomy some iterations between defining them and control schemes will be used. To this end, the first step in this Sub-Task is the overview of the analytical Balance Control Use Cases as presented in D3.1 [\[2\]](#). The basic information elements come from the UC templates included in that deliverable, and are the UC objectives and the step-by-step analysis of the individual processes. These data, in combination with the definitions and inventory of control triples presented in D5.1 [\[3\]](#), will be used in order for the consortium to identify and deduce the most appropriate control triples for the future Balance Control schemes.

The procedure is envisaged to have the following steps:

- Use of input data from Use Case analysis of D3.1
- Identification of control aims for each UC
- Identification and final agreement on the basic control loops that should govern the Balance Control UCs, with the aim of clearly identifying the input signals and the observables required for their effective operation
- Harmonisation of the finally identified control triples with the outcome of T5.1 and possible extension of the existing inventory of Control Triples.

In this context in the first part of this section we focus on the overview of the four Balance Control UCs by emphasising the control aims which are the key to devising the essential control loops involved in these UCs.

2.3.1.1 Balance Control UCs overview and basic control aims

According to the descriptions given in D3.1 [\[2\]](#) each type of Balance Control is concerned with one specific aim. Namely, the Inertia Response Power Control (IRPC) is intended for the very fast compensation of power imbalance in order to contain the Rate of Change of Frequency (ROCOF) during fast transients in frequency (both for small fluctuations in normal operation and large deviations due to contingencies). The Frequency Containment Control (FCC) is concerned with the compensation of the power imbalance and containment of the absolute frequency deviation (new

steady-state frequency value). The Balance Restoration Control (BRC) aims for the restoration of frequency to its nominal value based on the absolute deviation together with the restoration of Tie Line power flows after deviation from their scheduled values as a result of imbalance. Finally, the Balance Steering Control (BSC) is concerned with the regulation of power flows and, consequently balance within the Cell of interest.

Figure 11 shows the possible activation intervals of each control scheme over time. It should be pointed out that for the completeness and the most efficient operation of the Balance Control UCs and particularly for the cases of IRPC and FCC, in which the response of reserves should be fast and always available, both of these UCs ought to ensure a specific amount of two quantities, namely:

- Total Cell Inertia (H_C)
- Network Power Frequency Characteristic for a Cell (λ_i)

The total Cell inertia determines the contribution of each Cell to counteract a sudden frequency change. In a nutshell the higher the total inertia is, the more immune the system will be to sudden balance changes, thanks to availability of sufficient amount of reserves which can provide the instant power for compensation of emerging frequency transients and dynamics. In addition, concerning FCC each Cell can proportionally contribute to the Web-of-Cells Network Power Frequency Characteristic (NPFC or λ_u). The contribution of each Cell defines a NPFC for the Cell (λ_i), which determines the absolute deviation of the Tie Line power for a frequency change [11]. Evidently, the value of λ_i influences the amount of reserves that the FCC will provide and also the initial conditions for BRC. It is worth mentioning that a specific amount for both Inertia and NPFC can be determined by mechanisms which schedule the availability of these reserves (i.e. day-ahead or intra-day market processes) but the observation and control of these quantities allows each Cell Operator to regulate and ensure specific levels for these quantities in real time. In other words Cell Operators use control loops to compensate uncertainties in the values of H and NPFC that cannot be accurately determined by a market (or any other scheduling) process. The accurate control of these parameters by real-time loops is something crucial for the cell's stability because the time scales of these actions are too small for an operator to proceed to other corrective actions. Hence an accurate regulation of these parameters is a prerequisite. Therefore, taking into account the control aims of each Balance Control UC the following table (Table 2) which summarises the type and control objectives is obtained.

Table 3: Overview of Balance Control Use Cases and corresponding Control Aims

Type of Balance Control	Control Aim
Inertia Response Power Control (IRPC)	Objective 1: Reacts to frequency changes over time (frequency transient plus dynamic response) Objective 2: Observes and regulates in real time the available amount of inertia within a Cell
Frequency Containment Control (FCC)	Objective 1: Reacts to deviations of the frequency value so as to contain any change and stabilise frequency to a steady-state value Objective 2: Observes and regulates in real time the NPFC or λ_i within a Cell
Balance Restoration Control (BRC)	Reacts to absolute frequency deviations in conjunction with the tie line power flow deviations from the scheduled interchanges so as to restore both quantities to their initial values

Type of Balance Control	Control Aim
Balance Steering Control (BSC)	Regulates power balance within a Cell (proactively or reactively) in order to replace BRC reserves or mitigate potential imbalances in a cost effective manner

According to the conceptual implementation of the four schemes above and considering both the primary and secondary control aims each scheme has a specific activation profile which is shown in Figure 11:

- IRPC can automatically be invoked at any moment regardless of the system state (either normal operation or contingency) as long as frequency dynamic changes emerge due to imbalances or transients due to faults occur [12]
- BSC can also be invoked at any stage except right after an incident that triggers BSC activation only after FCC and BRC commencing.
- FCC is automatically commenced by an incident that leads to any frequency deviation beyond a threshold so as to maintain frequency stability [13].
- The combination of frequency and Tie Line power flow deviation leads to commencing of BRC after an incident. Invoking of BRC always follows that of FCC and it requires the frequency quasi-stabilisation.
- At particular time intervals the action of more than one controller may take place; however, only one is always predominant at a time.
- The operation of IRPC that aims at observing and regulating H_c and that of FCC responsible for observing and regulating λ_i are continuous apart from the intervals of imbalance contingencies where they should be inactive for security reasons.

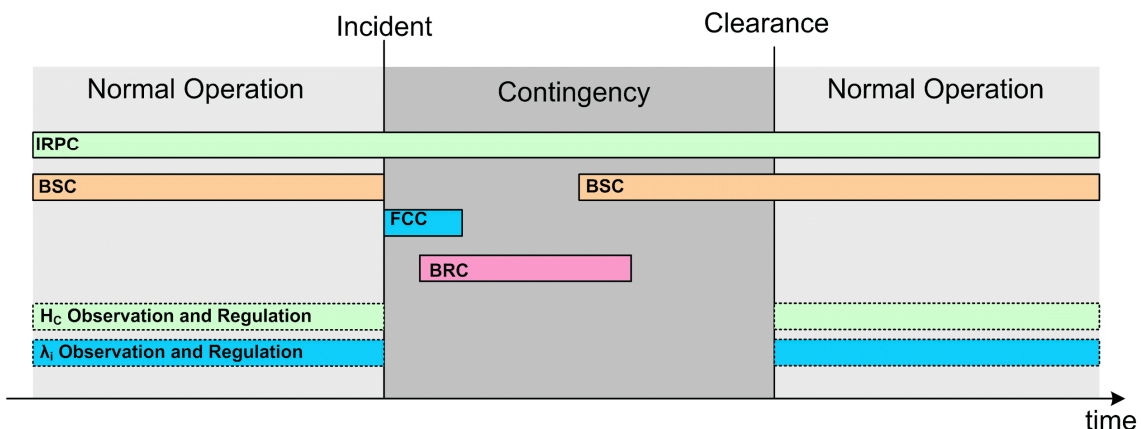

Figure 11: Activation timeframe for all four Balance Control schemes

2.3.1.2 Analysis of control aims and proposed basic control schemes

The analysis of the control aims and resulting operation of a system consisting of a Web-of-Cells is based on the following assumptions:

- The changes happening in the system refer mainly to dynamic stability (also known as small-signal stability) phenomena which assume that the imbalance disturbances are relatively small (e.g. loss of generator) compared to those disturbances caused for instance by faults [12] although the latter can also lead to loss of units after their clearance.

Therefore, all these phenomena result in frequency departures with the risk of instability [13] in which the analysis below refers to.

- The only control scheme that contributes to frequency transients compensation (i.e. due to faults) in terms of containment of rate of change of frequency is that of IRPC. Inertia as a physical property of synchronous generators intrinsically reacts instantaneously to transients of frequency (or more precisely to rotor angle deviations) caused by severe imbalances due to faults or less severe imbalances due to load/generation changes. Therefore, the future IRPC scheme, besides providing system support to dynamic stability, should also be able to provide system support in case of faults, helping the system to maintain stability until the fault is cleared.
- The system consists of interconnected Cells, forming a Web-of-Cells, via tie-lines the capacity of which can generally - but not exclusively - be regarded as small compared to the Cell rated power. As the main scenario of the analysis it is considered that the tie lines are not controlled whatsoever during incidents. This is a means of supporting unbalanced Cells by power contribution of neighbouring Cells [2]. However, for a more holistic approach in ELECTRA the scenario of tie-lines equipped with frequency decoupling systems or other type of control should also be considered in terms of the resulting observables and control triples.
- The disturbances in balancing may result in oscillations. As a matter of fact one or more Cells can be regarded as oscillating synchronously (all generators undergo the same frequency variations), simplifying so the analysis and the system representation. The specific assumption is made on the grounds that control areas in power systems analysis in literature are treated as a single entity in terms of frequency dynamics. This approach is also regarded for cells and, thus, a cell is governed by an equation of the following form:

$$\Delta P_{Gi} - \Delta P_{Di} = \frac{2H_i}{f_o} \cdot \frac{d(\Delta f_i)}{dt} + D_i \Delta f_i + \Delta P_{Tie,i} \quad (2.1)$$

where ΔP_{Gi} is the variation in generated power, ΔP_{Di} is the variation in consumed power, H_i is the cell's inertia constant, f_o is the nominal frequency, D_i is the load self-regulation coefficient, Δf_i is the frequency variation and $\Delta P_{Tie,i}$ the variation in the tie line power flows.

The control aim analysis is supported by a simplified example of 4 interconnected Cells under different operating and control stages. This example is shown in Figure 12 and it also helps explain the operation of BRC after an incident. Taking into account the above assumptions and the control aims presented in the previous section, the expected result of the first three Balance Control schemes, namely IRPC, FCC and BRC, on frequency is summarised in Figure 13. In particular, Figure 13 (top diagram) illustrates the frequency response of the Cell after an incident that results in frequency decline. Also, Figure 13 illustrates the corresponding total tie-line power flow deviation in the disturbed Cell and the effect of BRC on it after its activation. Obviously, if the tie-lines of the Cell are equipped with appropriate control system such as frequency transformer, HVDC link or other type of control, the deviation of the tie-line power will be zero (or less than a maximum depending on the control implemented). Therefore the scenario becomes simpler and only the unbalanced Cell undergoes frequency deviation, while the adjoining Cells remain unaffected. In other words, the unbalanced Cell is isolated in terms of reserves. This strategy has some trade-offs with regard to reserves within the Cell but ensures a more robust Balance Control for the Web-of-Cells. In any case it is a potential scenario and therefore it is taken into account not as a separate analysis but as special case of the main scenario. By contrast, BSC's aim is to steer power flows and, therefore, its control aim is separately depicted in Figure 14.

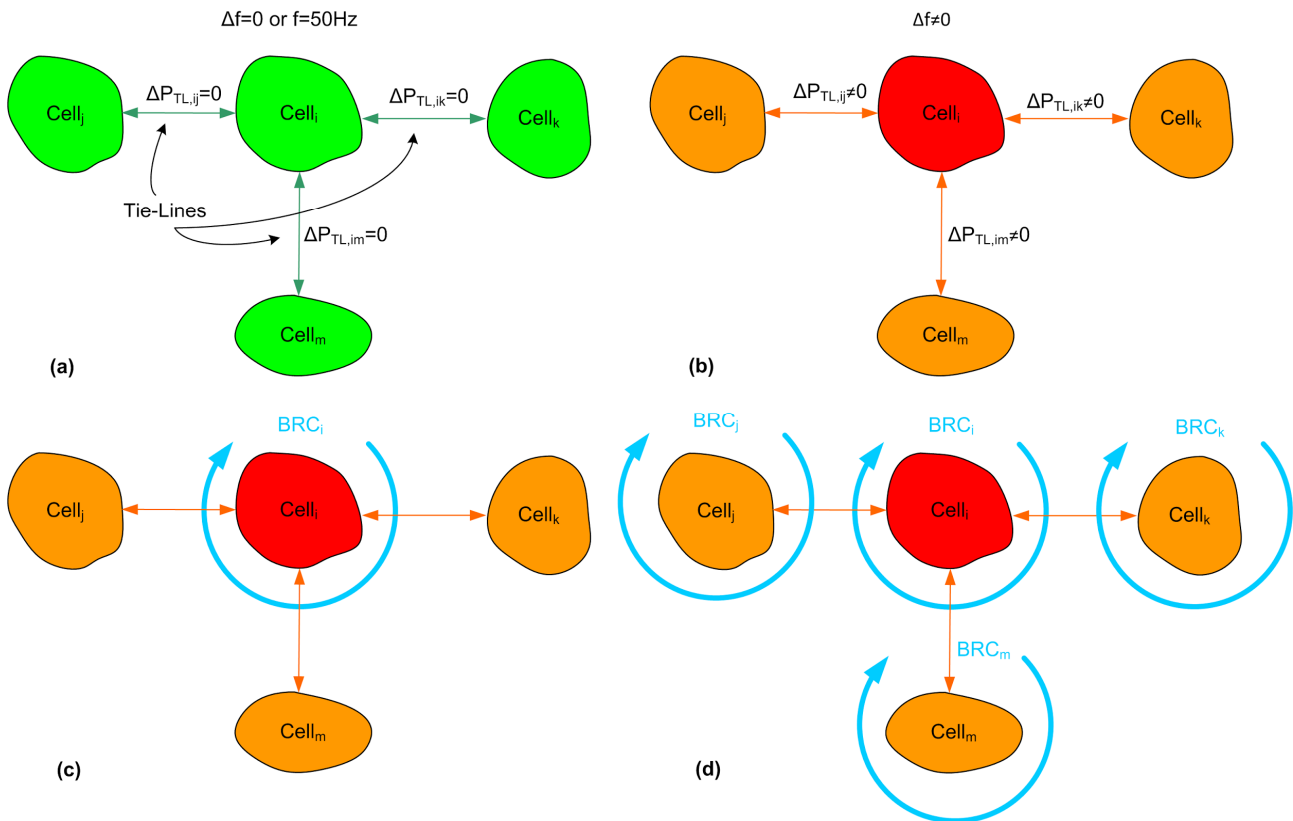

Figure 12: Example of four interconnected Cells through various operation and Balance Control stages

Initially, the system operates under a balanced state (Figure 12a) where both the frequency and tie-line power flow errors are zero. At $t=0$ a balance deviation, such as a load step change causes a power deficit in the central Cell. The disturbance will instantly initiate a frequency change which triggers the reaction of IRPC, and FCC in all four Cells. Therefore, at the first moments ($t < 5$ s) after the incident an activation of IRPC is expected in order to minimise the Rate-of-Change-of-Frequency (ROCOF). Although the dynamic response may vary for each Cell, the overall behaviour is similar and therefore an activation of IRPC and FCC reserves in all Cells is inevitable, unless the Cells are decoupled in terms of frequency as mentioned previously.

However, during the initial phase and due to the small difference between the actual and the nominal frequency, the contribution of FCC is rather negligible for all Cells until some time elapses. As the frequency deviation evolves and the ROCOF reduces, the contribution of FCC becomes predominant (same for all Cells) while IRPC wanes. As a result, the combined action of both controllers yields the minimum (or nadir) of frequency after a time t_{min} while, as can be seen in the bottom diagram of Figure 13, the total tie-line power flow deviation is positive $\Delta P_{TL,i} > 0$. The corresponding deviation for the adjoining Cells will be negative. The resulted situation is a stable situation (Figure 12b) in which the frequency is common for all Cells and the central Cell imports a part of the total power required for balancing from the adjoining Cells. Inevitably, the maximum frequency deviation value or $\Delta f_{i-dyn,max}$ in combination with the instant t_{min} that the nadir happens, constitute a means or metric for the performance assessment of both IRPC and FCC controllers.

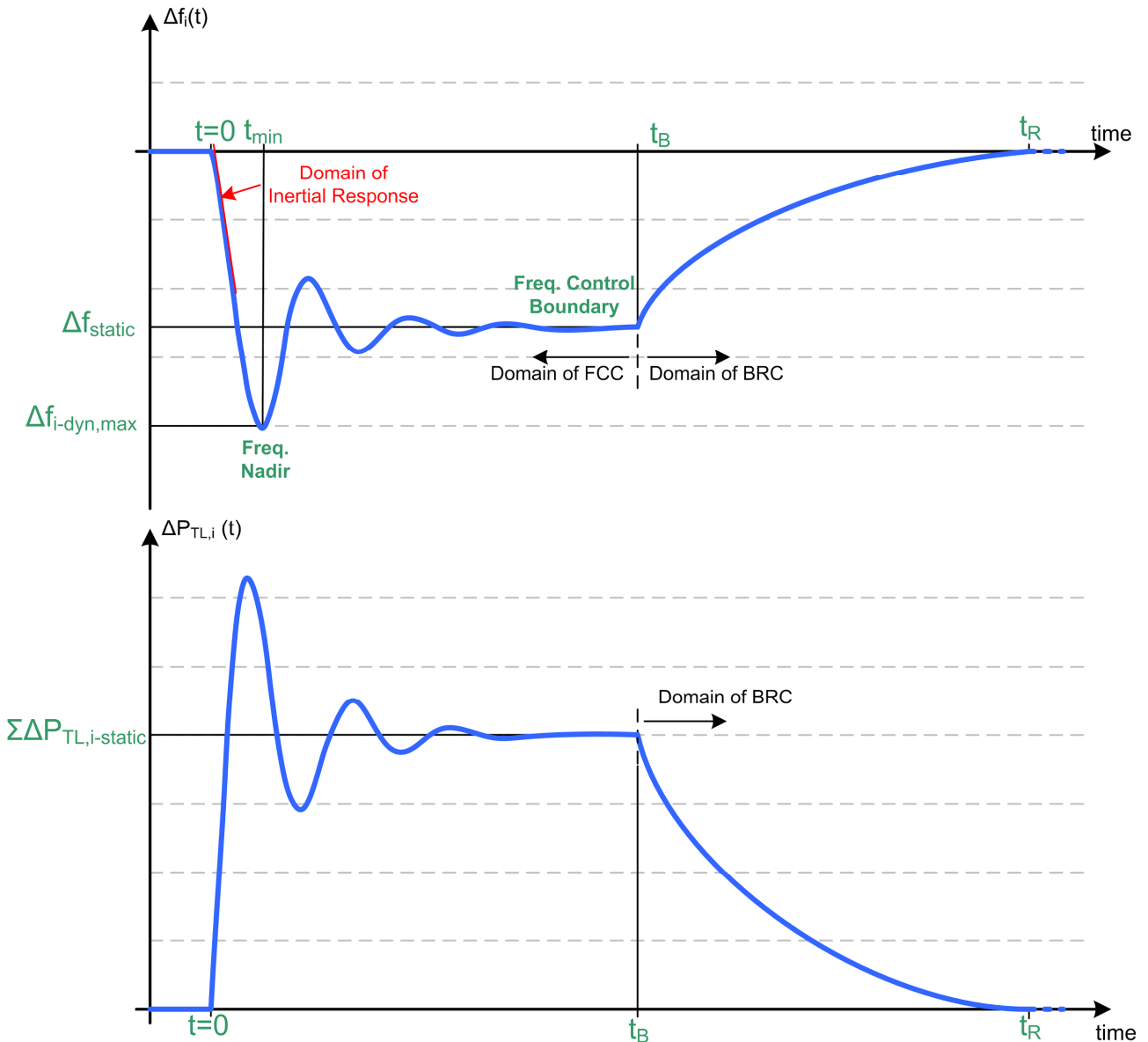

Figure 13: Evolution of frequency and tie-line power flow: control aim of combined Inertial, FCC and BRC over time after an incident within the unbalanced Cell

After the first phase has elapsed and the action of FCC leads to frequency stabilisation to a nearly steady-state value which is below the nominal one, the BRC takes over to restore both frequency and the tie-line power flows. This is assumed to happen after a time t_B (between 30 and 60 s), when BRC takes over so as to restore frequency and tie-line power flows to the initial values. This can be done either by activating the control scheme within the Cell that causes the imbalance [12] (unilaterally, Figure 12c) or by the coordinated activation of the adjoining Cells' BRC controllers too (Figure 12d). In any case, the activation of multiple BRC controllers should be such that the stability is not jeopardised [11]. Also, the key quantity that BRC should observe and try to minimise is the Balance Restoration Control Error, given by the formula:

$$BRCE_i = \sum \Delta P_{TL,i} + K\Delta f \quad (2.2)$$

This error is the equivalent to the Area Control Error and is independent of the control strategy that each BRC implements. It depends, however on the type (control) of tie-lines. If the tie-line power is controlled by one of the abovementioned methods, then the first terms of BRCE for the tie-lines

becomes zero, simplifying so the control objective. It is assumed that the BRC is completely inactive before the time t_B and the control constants are such that it is much slower than IRPC and FCC, avoiding so interference and potential instability issues.

The BRC process lasts until time t_R which is of the time scale of 300 seconds when the final Δf and $\Sigma\Delta P_{TL}$ values have to be zero before the BSC takes over. At this time, the BRC reserves of the central cell are still active, while FCC and BRC (if they are used in a coordinated control) of all adjoining cells will have become inactive due to their complete substitution. In this case the values of Δf_{static} , t_B and t_R can be used as metrics for the performance assessment of both FCC and BRC.

By contrast, the control aim of BSC partly differentiates from those of the other three control schemes. In particular, the scope of BSC is the fulfilment of specific active power set-points either in reactive or proactive mode, always ensuring the cost-effective operation of resources. In Figure 14 (top diagram) the reactive mode of BSC is illustrated. The process is the following: after time t_R has elapsed, the BS resources are gradually deployed so as to supplant the already deployed BR reserves. Obviously, this may entail a rescheduling of the tie-line power flows as well, but in contrast with the uncontrollable imbalance incidents, this is now done intentionally and without affecting frequency, in order to utilise the optimal resources and make BRC available for potential future incidents. Thus, the final goal, as shown in the top diagram of Figure 14, is the achievement of a specific aggregated active power level within the Cell for a specific time duration. During the activation of BS resources and until time t_S when the set-point is met, there is a simultaneous gradual withdrawal of BR reserves. The latter have to be synchronised and completely withdrawn at t_S as well so that there would be no control conflict which can lead to imbalance with subsequent frequency deviation. At present, the use of the corresponding Tertiary Frequency Reserves to substitute the already activated Secondary Frequency Reserves is mainly obtained manually. In the ELECTRA view of the future power system both controls will be automatic and, therefore, a good coordination of the control parameters is necessary so as to avoid potential conflicts or runaway effects that could pose a threat to the system stability.

The case of proactive use is separately shown in the bottom diagram of Figure 14. For the sake of simplicity and clarity a simple example has been considered. This diagram illustrates the power profiles of a Cell, including the aggregated generation P_G , demand P_D and tie-lines interchanges P_{TL} . Under normal operation all three profiles follow the scheduled ones leading to a zero or almost zero imbalance. This situation is shown with solid lines in the diagram.

However, it is possible that due to unpredictable intermittent behaviour of sources and loads deviations from the scheduled profiles happen. These are shown in dashed lines and result in imbalance values different from zero. The aim of BSC in this case is to intervene on time so as to supply with an opposite sign power and, hence, compensate imbalance. Therefore, the dashed parts of the imbalance profile line constitute the set-point profiles for the BS resources in proactive mode. It should be stressed that these profiles should be obtained by a short-term forecasting tool used by the Cell operator, rather than real-time measurements only. This means that the activation of BS resources should precede the imbalance deviation, in order to make sure that the activation happens on time and not with a time delay that could lead to frequency instability. Also, the effective deployment should be done by means of observing frequency deviations in order for the BSC to make sure that it does not deploy excessive amounts of resources that could have the opposite effect to the system balance. The accuracy and effectiveness of the BS resources deployment is achieved as long as frequency remains within pre-specified limits. Provided that, activation of other controllers such as FCC and BRC are avoided but even if that is not the case, the decrease of imbalance provided by BSC will mitigate the imbalance effects making the use of FCC more effective.

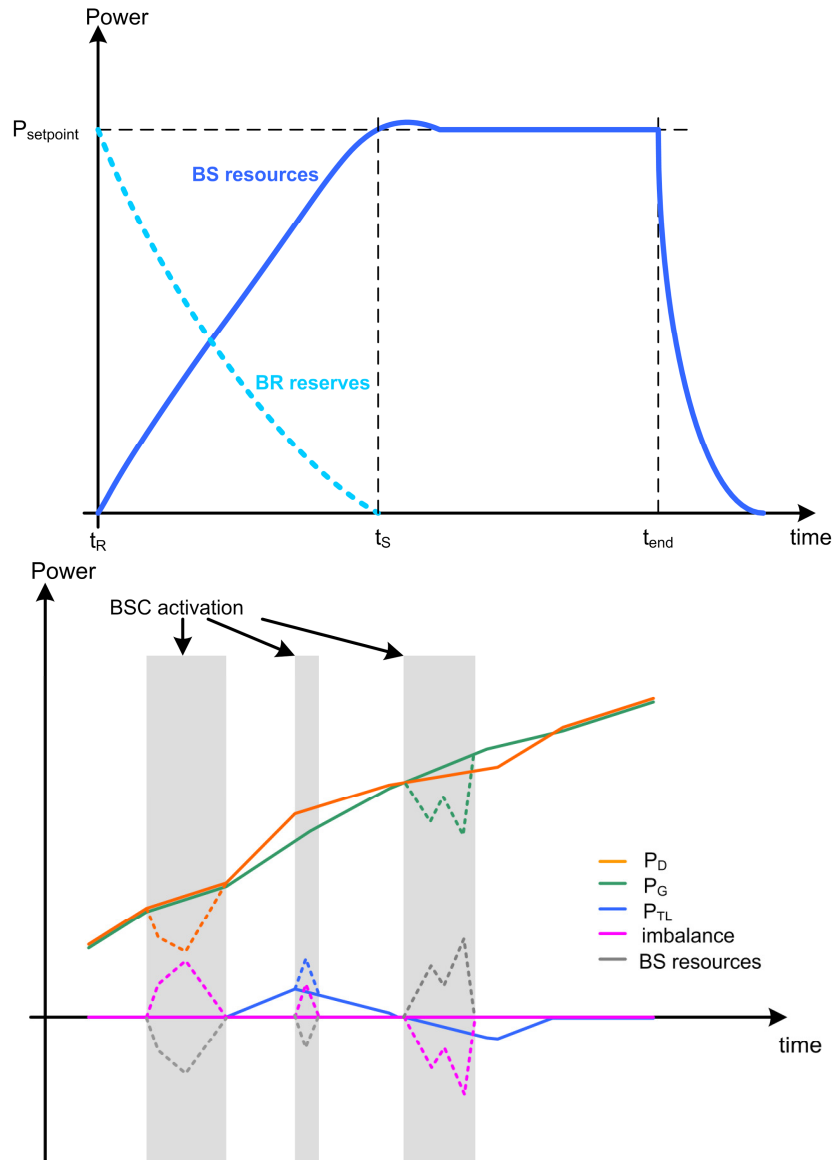

Figure 14: Evolution of real power and control aim of BSC in both reactive (top diagram) and proactive (bottom diagram) mode

Finally, one of the main objectives of Inertia Steering Control is to observe and regulate in real time the total inertia located within the concerned Cell. This distinction in responsibility level can be made due to the assumption that the dynamic frequency response may vary from Cell to Cell. Thus, as long as one frequency profile is assumed for one Cell, then the Cell operator by means of the control centre has the responsibility of observing and regulating the inertia which, in combination with FCC determines the most crucial initial frequency deviation (Initial ROCOF and minimum/maximum frequency). The importance of the first moments of a frequency deviation lie in the fact that protection systems may be affected by the initial response of frequency, leading to cascade effects and possible black-outs. In addition to the regulation of inertia, one of the most important Tasks for the stable system operation is the regulation of the Network Power Frequency Characteristic (NPFC or λ) and, particularly the contribution of each Cell to the total system λ_u which defines the contribution of Cells to the FCC. This latter process is also largely linked to control centre actions.

2.3.2 Methodology - Sub-Task 5.2.1. Identify needed Control Triples from Use Cases

The previous analysis, which focuses on the high-level description of control objectives, is used as the basis for identifying the needed control triples for the Balance Control UCs considered in ELECTRA. This identification is strictly related to deducing basic control block diagrams based on the control objectives description of section 2.2.1. These diagrams should be as general as possible in terms of the control blocks used, because the elaboration of them is part of other Tasks. These diagrams ought to explicitly depict the control aims, the observables towards those aims and finally the input signals that are required for the system to appropriately respond to the controller actions. These diagrams are to be analytically presented and explained per UC.

2.3.2.1 Definition of Observables needed

By means of the basic control diagrams derived from the control aims analysis it is possible to identify which physical or other quantities are necessary as an input signal for each controller. These observables will be obtained by actual measurements of voltages/currents at specific points in the Web-of-Cells using selected calculation blocks which are elaborated in the sections below. Each observable for each control loop constitutes the real signal which is compared with the reference value. For instance, with regard to FCC, the instantaneous frequency should be observed and compared to a reference value so as to calculate an appropriate active power set-point for a unit participating in FCC. The needed observables will be analytically presented for each UC and control scheme. The analysis is accompanied by theoretical models for defining these quantities.

2.3.2.2 Known Control Triples

After having identified the control aims, the basic control schemes and the needed observables, the last step in the process involves the identification of the input signal, needed to complete the identification of the control triples. As the system input signal we consider the physical quantity which is supplied to the system in order for the system to behave as determined by the control loop. Due to the generic nature of Balance Control the system that we consider in the analysis is the behaviour of Cells in the Web-of-Cells. This is assumed because balance control has system-wide effects. Also, the input signal in the vast majority of Balance Control loops is instantaneous active power. Having known the input signal in conjunction with the observable(s) and the control aim, a list of control triples is derived. Part of this comprises the already known control triples, also identified in the frame of T5.1 [3].

2.3.2.3 New Control Triples

The identification of new control triples for balance control requires a similar methodological approach as in the case of the known ones, with the exception that the exact details are defined by the previous methodology analysis in conjunction with the classification of control schemes in topology and time scale levels. In other words, the analysis takes into consideration the control objectives based on the high-level control aims of the four Balance Control UCs, and with the adoption of the topology and time scale levels specified in T6.2 [9] the new control triples are selected so as to meet the needs of the control implementations. The following assumptions are made:

- The resulting New Control Triples must be unambiguous with regard to selecting, implementing and testing each of them. Also, this is critical for the analysis of the WP6.2 control algorithms since there is a close interrelation between the two Tasks.
- In addition, they must be generic, which means that they should only refer to general implementation at each Control Topology Level and Control Time Scale.

- Each Balance UC which can be described by a set of cascaded controllers/systems will have to be sufficiently covered by relevant control triples at each individual level.
- Finally, wherever Known Control Triples fully or partly cover specific control requirements, these should be retained or used as a base to develop the corresponding new ones.

2.3.3 Methodology - Sub-Task 5.2.2.Determination methods for specific observables

2.3.3.1 Algorithms

In the Spreadsheet "Use Cases-Control Triples" Tab: "[WP5 Observable Algorithms](#)" [18] relevant observables for the ELECTRA Use Cases are listed.

New observables like e.g. the local power balance of a grid part or the inertia response power to be delivered to counteract frequency changes call for faster and more accurate information about the actual value and the frequency of voltages, currents and power. There is a need to know these values on a time scale of one or a few cycles and sometimes even within one cycle. An assessment will be made of the Clarke and/or Park transformations as an adequate technique to meet these requirements. The requirements for the acquisition of these values will be investigated as well as the requirements for the post-processing in order to derive meaningful observable values.

The situation at normal operation of the grid is investigated as well as circumstances where the phase quantities are heavily distorted or deviating strongly from rated values.

2.3.3.2 Determination methods for specific observables

Active and reactive power are conventionally defined in the time-domain implying sinusoidal voltages and currents. The definition of instantaneous active power is just the multiplication of voltage and current. Reactive power is defined for a whole sine voltage period as the maximum value of the corresponding actual power, which has an average of zero. Inertial response power is proportional to the time derivative of grid frequency, which counteracts changes in grid frequency.

Akagi and other authors [17] have developed the concept of instantaneous (reactive) power. This concept starts with decomposition of instantaneous power and current into real and reactive components, according to Clarke or similar transformations. The significance and usefulness of this concept will be investigated for defining instantaneous values of other quantities like frequency and inertial response power.

2.3.3.3 Measurements

The observability functions are fundamental elements in monitoring the secure operation of a power system, since they enable to estimate the system state. Adequate and reliable measurement devices are needed that monitor the variables describing the network operating point, for example: currents, voltage, frequency, active and reactive power, etc. These variables are *permanently* measured and compared with setpoints or thresholds beyond which the situation is defined as abnormal and can lead to instability. When a deviation from normal operation, or even a contingency, occurs, the controller device issues a signal operating a flexible source.

Permanent monitoring of the network's electrical values by reliable and proper measurement devices supplying controllers is a key element of the control loop of the Balance and Voltage Control schemes allowing a rapid reaction and the stabilization of the network.

So, the definition of the measurements requires a strict technical specification of the measurement devices. The document in the “[Annex: The measurements chain in function of control objectives](#)” provides some basics when defining the measurements chain: current and voltage transformers, analogical to digital conversion and calculation algorithms.

The next figure presents the general block diagram of the whole measurement chain. The first elements of this chain are the measurement transformers. The values of voltage or current in an electrical network are too high to permit convenient direct connection of measuring instruments or relays. Measurement transformers are then required to produce a down-scaled replica of the input quantity (to the accuracy expected for the particular measurement, of course).

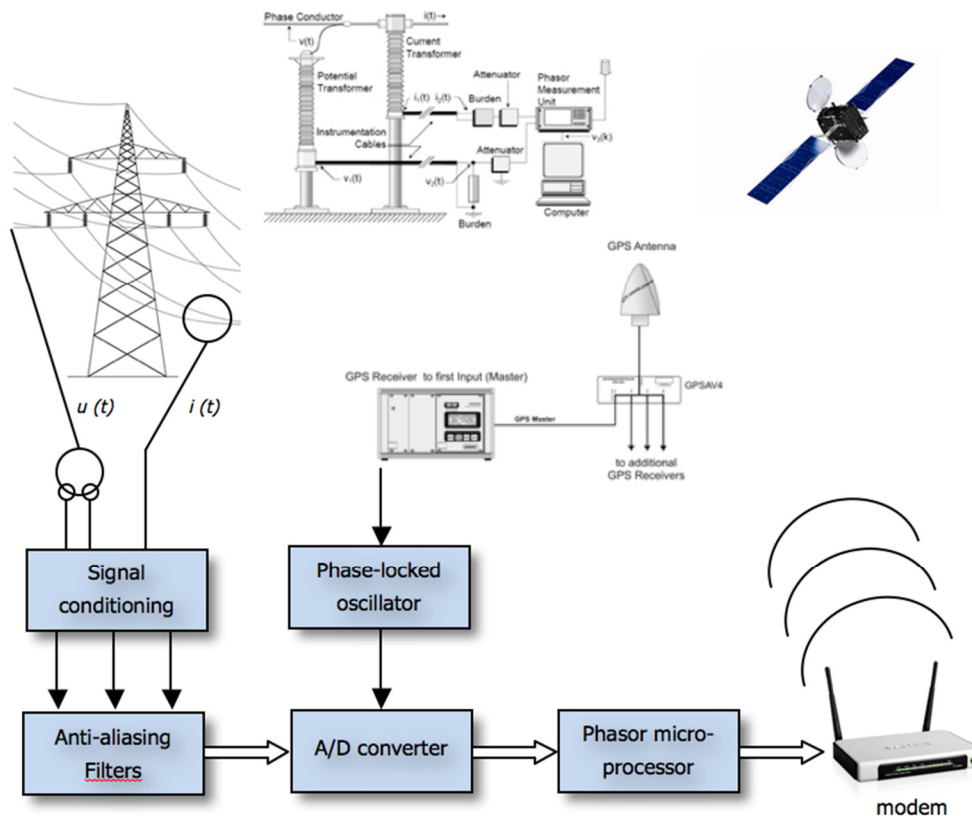

Figure 15: General block diagram of the measurement chain.

The performance of measurement transformers during and following large instantaneous changes in the input current or voltage is important, in that this input may depart from the sinusoidal waveform. The deviation may consist of a step change in magnitude, or a transient component that persists for an appreciable period, or both. The measurement transformers and the whole measurement chain are required to operate accurately during the period of transient disturbance characterizing the network contingency. An error in the measurements may abnormally delay the operation of the controllers or cause unnecessary operations.

The measurements of currents and voltages are then conditioned before being converted to digital values by Phasor Measurement Units (PMU). Signal conditioning may be necessary if the signal from the measurement transformer is not suitable for the Data Acquisition hardware being used. For example, the secondary current given by the CT will be converted into a voltage signal that will be easily handled by the A/D converter. The signal may also need to be filtered to limit the bandwidth (anti-aliasing filter and data sampling frequency satisfying the Nyquist criterion) and avoid errors in the digitization process.

The data acquisition process and the synchronisation of the measurements are then realised by PMUs. The PMUs are power system devices that provide synchronized measurements of real-time phasors for the voltages and the currents. Synchronization is achieved by same-time sampling of voltage and current waveforms using timing signals from the Global Positioning System (GPS) Satellite. Time synchronization allows synchronized real-time measurements of multiple remote measurement points on the grid.

Data acquisition is the process of sampling the input signals – voltage and current – and converting the resulting samples into digital numeric values that will be treated by a computer to determine the observables. This process is illustrated in the figure below.

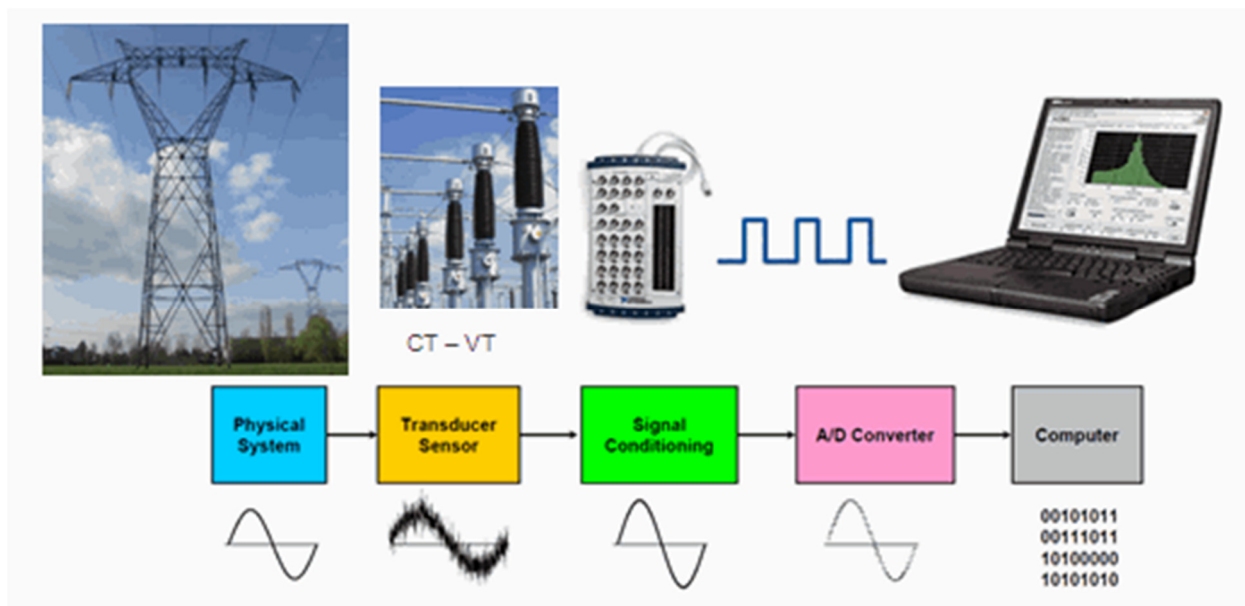

Figure 16: Data acquisition process.

A phasor is a complex number that represents both the magnitude and phase angle of the sine waves like the currents and the voltages. The most common technique for determining the phasor representation of an input signal is to use data samples taken from the waveform, and apply the Discrete Fourier Transform (DFT) to compute the phasor. Sample frequency could vary, regarding the level of supervision needed (voltage or balance control).

Phasor measurements that occur at the same time are called "synchrophasors". Phasor measurements are sampled from widely dispersed locations in the power system network and synchronized from the common time source of a Global Positioning System (GPS) radio clock.

PMUs measure voltages and currents at critical points on the power grid and they output accurately time-stamped voltage and current phasors. Because these phasors are truly synchronized, synchronized comparison of two quantities is possible in real time. These comparisons can be used to assess system conditions such as frequency and voltage changes. The phasor data is collected either on-site or at centralized locations using Phasor Data Concentrator (PDC) technologies and Supervisory Control and Data Acquisition (SCADA) systems. The data is then transmitted to a monitoring system allowing the computation of the observables (for different control triples and the control of the power flows on the network).

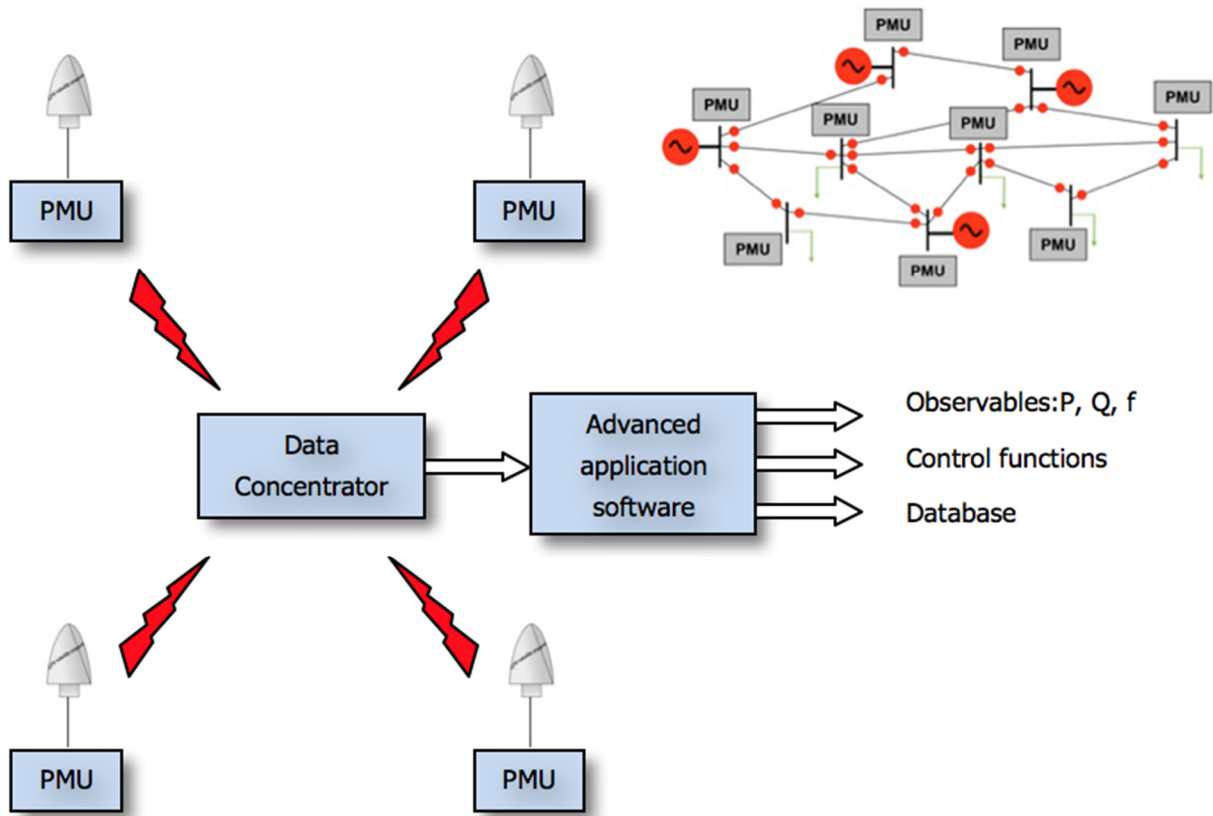

Figure 17: Integration of PMUs in the power systems.

The requirements for IT infrastructure to guarantee 'real time' data exchange are out of scope in this document but it is worth to mention the application of IEC 61850 protocol that is of great interest in electrical power systems for data communication systems between substations. This IEC 61850 protocol offers new possibilities for real-time communication performance between Intelligent Electronic Devices (IEDs) within substation and between substations and the observation and monitoring center because of the Generic Object Oriented Substation Event (GOOSE) messages.

Reliable measurements should also provide quantification of measurement error. This error could vary, as a function of the level of supervision and the precision required for the observables algorithms of each control triple.

2.3.3.4 Numerical reliability tests

As explained in the previous paragraphs for Balance Control, some of the new observables need to be defined as instantaneous values if possible. Therefore the algorithms determining these could suffer from background noise that is not cancelled by some averaging procedure. As e.g. inertial response power is proportional to the time derivative of instantaneous frequency, also numerical noise may be a serious problem.

The verification of the numerical reliability and the robustness of the algorithms will be done in the following two steps:

- Identification of the influencing factors (background noise, numerical noise, bad input data, measurement errors, etc.)

- Sensitivity analysis of the identified factors: how the variation of each one is affecting the output of the algorithms. (The observable calculation and the entire basic control loop convergence.)

Results of the tests can provide the first insight to improve the algorithms on one hand, and/or apply appropriate measures during the measurement acquisition phase (for example, filtering) on the other hand. Normally a more robust algorithm costs more computationally, which maybe is not a problem for a basic control loop but can become an issue when the number of network nodes (and controllers) increases.

2.3.4 Methodology - Sub-Task 5.2.3. Basic control loop simulation, based on chosen Control Triples

2.3.4.1 . Basic control loop simulation

In the frame of this Task a set of simulations is planned. The simulation tests aim at providing a means of assessment of the selected Control Triples and particularly how the observables' algorithms perform within a closed-loop system. For the generic control loops describing each Balance Control UC, specific simulation models will be developed, to provide a testing environment for the evaluation of consistency and effectiveness of each control triple. Obviously, particular care will be devoted to the algorithms/methods selected to measure/calculate the specific observables and how these observables' blocks interact with the relevant control algorithms. In this context the specific Task will have to take into consideration the outcomes of three Sub-Tasks:

- The identification of observable algorithms (in conjunction with the relevant control triples),
- The SRPS (Single Reference Power System) analysis, and
- The controllers' analysis provided by WP6.

Concerning SRPS analysis, a (set of) solution(s) with regard to the power system models that can be used will be considered. In fact, the analysis should assume simplified representations of power systems sufficient to provide the information/behaviour necessary to test the observables algorithms. This approach is expected to:

- Minimise efforts of setting up and modifying the system model
- Minimise simulation tests time
- Increase test repeatability

In addition, from the outcome of T6.2 an exhaustive list of control algorithms will be derived. This list can be used by the T5.2 working group in order to opt for the most appropriate control blocks to be tested together with the observables' blocks. Since the focus will not be the elaborate analysis of controllers themselves (this is part of WP6), the controllers selection should be made based on the above mentioned facilitation criteria to this Task's tests.

It is worth noting that as far as this is necessary initial tests with simplified input signals can be implemented as first-round of tests for observables' algorithms (e.g. variable frequency signal generator to test PLLs).

2.3.4.2 Reliability test

The overall methodology for the reliability tests will be similar to that outlined in [section 2.3.3.4](#) for the numerical reliability testing. However, new influencing factors to consider can appear when the algorithms are implemented in a real hardware prototype at laboratory level. In addition, tests shall be performed in normal and undesired conditions (reproducing some disturbances, for example). A clear test plan shall be prepared for guiding the tests and collecting the results.

2.3.5 Methodology - Sub-Task 5.2.4. Hardware test (lab table)

2.3.5.1 Lab table programmable unit test to be transferred to WP7

As described in Chapter [2.2.2.](#), simulations will be primarily performed with power system simulation software tools. The decision about which simulations will be implemented in hardware and elaborated in lab tests will be taken when all test cases are defined and the capabilities of the evaluated hardware test platforms are evaluated [\[8\]](#).

The interface between the software simulation and the hardware simulation depends on the type of simulation and the type of hardware. Therefore the unit test input and output signals and parameters have to be developed from the test cases for each individual simulation. A comprehensive documentation of the test cases provides all information needed for software as well as for hardware simulations.

The following points have to be elaborated to gain the test setup for the testing hardware from an existing test case:

- Define the lab wiring according to the grid model and the impedance parameters given by the models defined in the test case
 - Define the involved component(s) and measurement device(s)
 - If the grid model has to be reduced to be realizable in the lab, the simulated grid impedance has to be calculated.
- Realize the test setup
- Configure the devices
 - Configure the grid simulator(s) for all relevant parameters according to the time series given by the test case.
 - Configure the measurement device(s) according to the parameters defined in the test case.
 - Configure the testing hardware according to the parameters defined in the test case.

2.4 Methodology - Voltage Control

2.4.1 Used Methodology

The application of a general methodology to the Voltage Control UCs is parallel to the previously explained in section 2.2.1 of this deliverable for balance control. The identification of the control triples (control aim + observable + input signal) required to fulfill the objectives of the future voltage control schemes roots on the identification of the basic control loops for every Voltage Control UC. The UCs details were shown in D3.1 [\[2\]](#), but here, a reminder will be done in the following section, in order to get the essential information for the identification of the control triples that will be implemented in future voltage control schemes.

The process to reach the expected results can be summarized as follows (see also Chapter [2.1.2. Working procedure for selecting observables and their algorithms](#)):

- Identification of the control aims from the Voltage Control UCs.
- Identification of the different basic control loops for every UC, depending on the technology and the specific observables needed for the control of the distributed generation units.
- Harmonization with the results from T5.1 and extension, if necessary, of the existing inventory of control triples.

2.4.1.1 Voltage Control UCs overview and basic control aims

From D3.1 the necessary information about the Voltage Control UCs can be collected. The novel control scheme proposed for voltage regulation in 2030+ grids is intended to be accomplished in two steps: primary voltage control (PVC) and post-primary voltage control (PPVC). This means that the mechanisms for voltage control are simpler if compared with the ones required for Balance Control. On the one hand, the control aim for primary control is the stabilization of the voltage level at the nodes of the cells in case of a severe disturbance by adjusting the reactive (or active) power exchange at the point of interconnection with the device. On the other hand, the PPVC aim is the restoration of the voltage levels in the nodes of the Cells to their rated values (within a safe band) while optimizing the reactive power flows. A summary table of the voltage control UCs and their control aims is reported in Table 3. As a consequence a reduction of the losses of the network is achieved. This two-step voltage control scheme, by using the capabilities linked to the Web-of-Cells (mainly the high observability and monitoring of the Cells and the tie-lines for all voltage levels) will allow a safe, reliable and efficient voltage control mechanism. This voltage control hierarchy presents the advantage of being finished in only two steps as one of the main differences if compared with the current scheme.

Table 4: Overview of Voltage Control UCs and corresponding control aims

Type of Voltage Control	Control Aim
Primary Voltage Control (PVC)	Objective 1: Reacts in case of voltage deviations detected in any nodes of a Cells as a consequence of a severe disturbance Objective 2: observes, monitors and regulates the voltage levels deviations in real-time in the grid nodes within the Cells
Post-Primary Voltage Control (PPVC)	Objective 1: Restores the voltage levels in the grid nodes to the set-point values within in a safe band Simultaneously, it optimize the reactive power flows in the system. Objective 2: regulates the voltages in the nodes in case of generation-demand imbalances

The PVC is an automatic control scheme that operates in case a deviation over the voltage set-points is detected in any node of the Cell. The activation of the reserves for the provision of this service has to be accomplished in the range of milliseconds. Each Automatic Voltage Regulator (AVR) type unit is responsible of its contribution to the PVC. The mechanism for the provision of PPVC reserves is more complex. Every Cell must have its own reserves but due to security or economic reasons, it can utilize reserves placed in its neighbouring Cells, by previous checking of the tie-lines transport capacities and the security of the reserves switching operation.

Considering the activation timeframes for the voltage control mechanisms, a timeline with the interactions of the voltage controls and the event that triggers their operation can be observed in Figure 18.

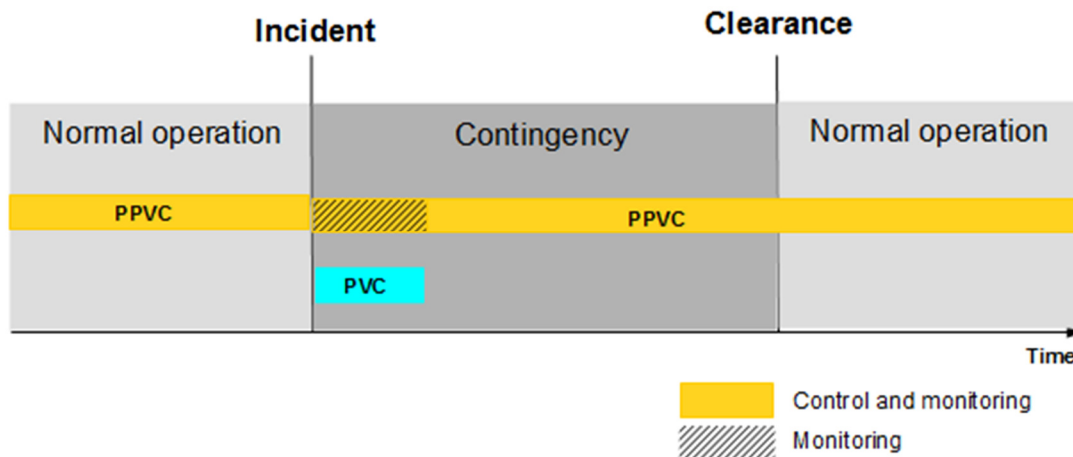

Figure 18: Activation timeframes for voltage control schemes

2.4.1.2 Analysis of control aims and proposed basic control schemes

The analysis of the control aims for the Voltage Control use cases is based, of course, on the application to the Web-of-Cells architecture, i.e. to a system formed by a group of interconnected Cells (the Web-of-Cells), linked by means of tie-lines (see details in D3.1 [2]) and such that the capacity for transporting active and reactive power by the tie-lines connected to a Cell is small if compared with the availability for active and reactive power provision within each Cell.

The operation mechanism is summarized as follows. At $t = 0$, a voltage disturbance is produced in the system, for example a voltage dip. As a consequence, at the point of the grid where the incident has occurred, there will be a sudden voltage drop that will spread to the whole Cell and it could affect a larger area than the Cell itself. This will cause the alteration of the voltage levels in the nodes of the neighbouring Cells of the node with the primary disturbance too. The detection of the voltage deviation in any node of any Cell will automatically trigger the primary voltage control in the units with the possibility to provide this service. The expected results of the activation of the voltage control mechanisms in a Cell are shown in Figure 19. In one of the nodes a deviation of the voltage over the setpoint (V_{st}) is detected. The PVC activates the resources in order to bring back the voltage to the safe band delimited by the minimum (V_{min}) and maximum (V_{max}) in a recovery time (t_{rec}).

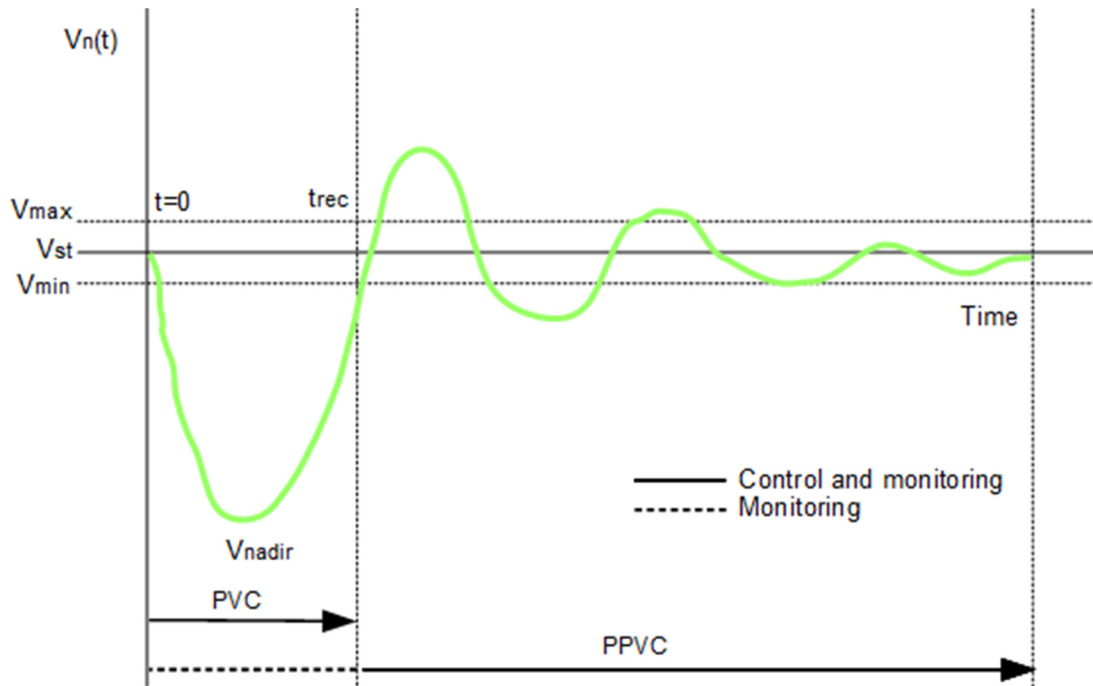

Figure 19: Evolution of rms voltage profile and voltage control domain.

Figure 20 shows the operation of the voltage control mechanisms in a simple system of 4 interconnected Cells, where the application of the subsequent control stages (PVC+PPVC) will be deployed. The goal is to show, in a simplified way, the interactions as a result of the coordination of the Cells' operation in case of an event in one of the Cells, in this case named as CC_i . CC_j , CC_k , and CC_m represent three neighbouring Cells electrically connected to CC_i through one or several tie-lines. The exchange of reactive power between neighbouring Cells has been notated with the initial and the final letter of the Cells that join. This way, Q_{ij} will represent the reactive power flow between the Cells i and j . As the purpose of this section is to show a general example of the operation mechanisms, the direction of the reactive power flow is not indicated by the order of the letters in the subscripts. Figure 20 a) displays the initial state of the Web-of-Cells, initially operating at a balance state, corresponding to the schedules and with the voltages in the nodes according to the set-points defined by the Cell Operator. The reactive power flows in the tie-lines interconnecting the Cells are established to maintain the safe and reliable operation. Those reactive power flows in the lines are assumed to have been previously fixed (a range or a maximum value) by agreement of neighbouring Cell operators due to technical or market considerations. The voltages in the nodes (V_{st}) are settled to the values resulting from the last optimal power flow accomplished in the system (state 0). The reactive power flows in the tie-lines can be (ideally) zero or be determined at a value previously agreed with neighbouring Cell operators. It has to be highlighted that, in this example, the reactive power flows only have been considered, but the voltage control at medium or low voltage levels can also be controlled by means of the active power flows. At $t = 0$, a deviation over the voltage set point in one of the nodes of the system is detected (V , Figure 20a)), triggering the activation of the primary voltage control mechanisms. During those first moments after the event (in the order of milliseconds), the primary voltage control of the AVR-type units tries to contain the voltage drop and to stabilize the voltage in order to avoid a voltage collapse. This means that in Figure 20b) a steady point is reached but out of the optimal for both the voltage levels in the nodes and the reactive power flows in the tie-lines. The AVR's action is very fast, so the time gap between the command signals sent to

the primary controllers and the effective activation of the voltage regulators can be considered negligible. As a consequence of the disturbance, the power flows between CC_i and its neighbours are also altered. The PPVC of the Cells enters into force at time t_{rec} , and by the resolution of the optimal power flow considering the restrictions imposed by the tie lines, the PPVC control determines the new optimal voltage set points (and active power set-points if necessary, in LV networks for example) and the novel flow exchanges by the tie-lines (state 1). After the operation of the devices with PPVC control, the new equilibrium defined by the state 1 is reached.

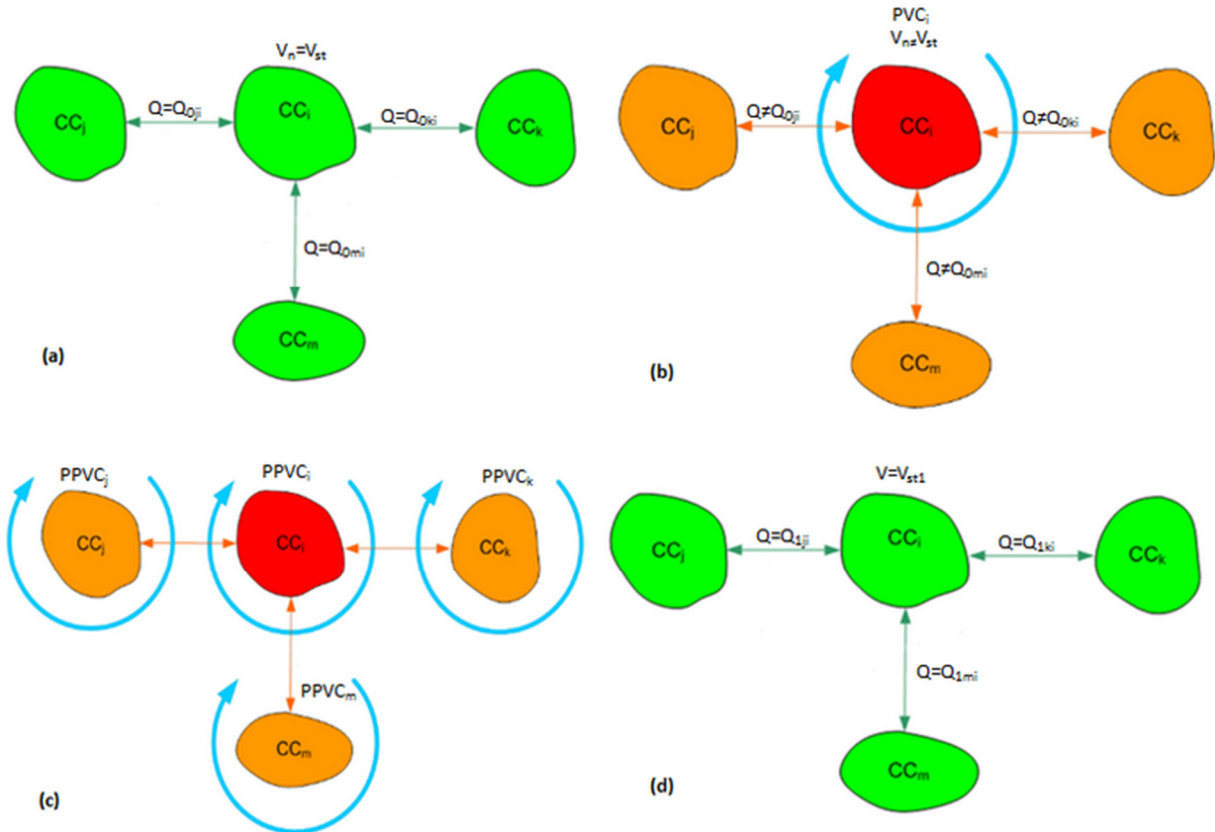

Figure 20: Example of four interconnected cells through various operation and Voltage Control stages.

Depending on the characteristics of the Cells as well as their voltage levels, the voltage deviation can be partially compensated by the operation of devices with active power regulation in primary voltage control acting times, such as the inverter-based devices, the flexible loads or the energy storage systems. This is the reason why, for the voltage control, there is not an inverse relationship between the voltage drop and the increment/decrement of reactive power circulating through the tie-lines, because active and reactive power can be coupled magnitudes.

2.4.2 Methodology - Sub-Task 5.2.1. Identify needed Control Triples from Use Cases

The previous high-level description of the control mechanisms of the Voltage Control Use Cases is used again as the basis for identifying the needed control triples considered in ELECTRA. In this process, several basic control block diagrams can be deduced, which will be elaborated in other Tasks. In Task 5.2 the diagrams will serve to extract the “control aims”, the “observables” towards those aims and the “system input signals” required for the system to appropriately respond to the controller actions. These diagrams are explained for the PVC (distinguishing the different technologies that can be employed) and PPVC use cases in Chapter 5.

2.4.2.1 Definition of Observables needed

By means of the basic control diagrams derived from the control aims analysis it is possible to identify which physical or other quantities are necessary as input signals for each controller. These observables will be obtained by actual measurements of voltages/currents at specific points of the cell in the Web-of-Cells using certain calculation blocks. Each observable for each control loop constitutes the real signal which is normally compared with a reference value to get an appropriate set-point to be followed by a resource participating in control (PVC use cases); a simple example of such a set-point can be a reactive power set-point for a DER unit, in case of PVC. In the case of the PPVC, the comparison with a reference value is not so clear since the observable (after some additional processing) is used within an optimization algorithm (OPF) to obtain the optimal control action. Chapter 5 presents the involved observables per use case and control scheme.

2.4.2.2 Known Control Triples

After having identified the “control aims”, the basic control schemes and the needed “observables”, the last step in the process involves the identification of the “system input signal”, needed for the identification of the “control triples”. The system input signal is the physical quantity which is regulated in order for the system to behave as determined by the control loop, and clearly has an effect on the observable. In general the “system” is the Web-of-Cells, but can be reduced to a cell level for the Voltage Control Use Cases. The first analysis of the control triples for the Voltage control use cases was performed in the frame of T5.1. Known control triples are specified in D5.1 [\[3\]](#) for the primary, secondary and tertiary voltage control, which will be further refined and developed and where necessary modified in this Task T5.2 for the proposed PVC and PPVC.

2.4.2.3 New Control Triples

The analysis carried out in T5.1 must be extended and where necessary adapted from the former primary, secondary and tertiary voltage control to the new PVC and PPVC mechanisms activated under the Web-of-Cells architecture and described in section 2.4. In addition, T6.2 provides a classification of the control schemes according to control topology levels (CTL) and control time scales (CTS), which must be considered during the identification of new control triples (to keep coherence in the ELECTRA developments and the alignment of the activities):

- CTL0: single physical device level
- CTL1: aggregated flexible resource level
- CTL2: cell level
- CTL3: inter-cell level

- ❖ CTS0: system response (5 s)
- ❖ CTS1: primary level (30 s)
- ❖ CTS2: secondary level (120 s)
- ❖ CTS3: tertiary level (900 s)

The resulting New Control Triples must be very specific so that there are no ambiguities with regard to selecting, implementing and testing each of them (considering also the implications for WP6).

2.4.3 Methodology - Sub-Task 5.2.2.Determination methods for specific observables

2.4.3.1 Algorithms

In the Spreadsheet "Use Cases-Control Triples" Tab: "[WP5 Observable Algorithms](#)" [18], the observables for the Use Case of Post Primary Voltage Control (PPVC) in the Web-of-Cells are:

- Collection (vector) of apparent power [VA]
- Collection (vector) of voltage phasors [V, rad]

These vectors are input to a State Estimator in order to find an optimised solution for the set-points of node voltages and branch apparent powers, all in complex form. This requires the definition of objective functions to be minimised, e.g. power dissipation by reactive current. Several forms of these functions are to be investigated, in order to arrive at an unambiguous formulation that will apply in most cases in the Web-of-Cells.

In case these objective functions have definite relations to the vectors mentioned above, these may be defined as observables themselves. However this is not the case when values depend on predictions, thereby making the outcome explicitly dependent on time instead of past measured values alone.

The Primary Voltage Control (PVC) has not been considered here since not disruptive changes are expected from current practices.

2.4.3.2 Determination methods for specific observables

These vectors of powers and voltages require many measurements at grid nodes and between nodes. Next these vectors are to be processed by a State Estimator (SE) and/or an Optimal Power Flow (OPF) solver. Although the objective functions for the OPF can be modelled on the basis of a (partially known) grid model, these functions also can be measured directly. This would require measurement of voltage in every node, and a measurement of complex power in every branch between nodes. Next the dissipation due to reactive currents may be calculated for the whole system, and minimised dynamically in the control loop, thereby making State Estimation unnecessary.

2.4.3.3 Measurements

The methodology for the measurements in Voltage Control here is similar to that described for Balance Control in paragraph [2.3.3.3. Measurements](#).

The methodology consists in measuring the current and the voltage by means of measurement transformers. An A/D converter and a data acquisition process sample the analog input signals – voltage and current – and convert the resulting samples into digital numeric values that will be treated by a Phasor Measurement Unit (PMU). The PMU provides synchronized measurements of real-time phasors for the voltages and the currents.

The sampling frequency could be adapted in function of the control triples, but practically, the Phasor Measurement Units always work with the same sampling frequency, independently of the observables that have to be computed. On the other hand, the algorithms for the observables will use average or cycle values (e.g. 10-cycles average values or 3 seconds average values) depending on the needs for the control triples.

2.4.3.4 Numerical reliability tests

For Voltage Control, vectors of many observables, e.g. voltage phasors and reactive power, need to be defined at the same instant of time, if possible. For consistent control, the data needs to be collected efficiently over the grid area considered and transmitted to the controller with a sufficiently small time delay. The influence of errors in recording time due to the failure or absence of a central time reference needs to be small enough to provide a consistent dataset to the controller at all times.

2.4.4 Methodology - Sub-Task 5.2.3. Basic control loop simulation, based on chosen Control Triples

2.4.4.1 Basic control loop simulation

The simulation of the basic control loops for the Voltage Control Use Cases within Task T5.2 has a dual purpose: on the one hand, the evaluation of the methods/algorithms that calculate an observable from the measurements in the Web-of-Cells; on the other hand, the analysis of the behaviour of the observable in a closed-loop control and the possible interactions between the algorithm for the calculation of the observable and the control loop itself. With the results obtained by the simulations the suitability of the identified control triples can be assessed. The simulations will be developed for control loops defined for the Voltage Control Use Cases. These basic control loops are also shown in this deliverable in Sections 5.1 and 5.2.

For the final accomplishment of the simulations, we have to define:

- The observables that, based on the measurements, serve as controlled variables
- The controllers for any of the elements that are part of the power system. The inputs that go to the Web-of-Cells from the output of the controllers, taking into account the control topology level.
- The simulation models for representing the elements of the grid with a suitable level of detail. The model should reflect reality but be simple enough in order not to introduce additional uncertainties that could disturb the behaviour of the control loop.

The Single Reference Power System (SRPS) approach used for providing these simulations models is described in more detail in the chapter [2.2.1.3. Define small test grid in SRPS](#).

2.4.4.2 Reliability test

For the testing of the numerical reliability of the observables the plan is to test the observables identified in Sub-Task 5.2.1 using the basic control loops developed in Sub-Task 5.2.3. The algorithms used for calculating the observables will be provided in the current Sub-Task (5.2.2)

The reliability test will be performed as a sensitivity analysis on various parameters that can influence the observables ability to perform in the control loop. In the analysis we will investigate the relative change in output of the controller due to a small change in relevant parameters and how much a parameter can be changed before the control loop becomes unstable.

The parameters that will be investigated are:

- Noise on the input to the observable algorithm
- Noise on the output of the observable algorithm
- Time delay from the measurement to the observable algorithm
- Time delay from the observable algorithm to the controller

- Tuning parameters of the observable algorithm
- Lack of synchronisation of the voltages/currents measured in the different nodes of a cell (for the PPVC control mechanism)
- Network model errors (for the PPVC mechanism)

In some cases it may also be interesting to test the algorithm on different controllers and different devices if the same observable can be used for different controllers or devices.

2.4.5 Methodology - Sub-Task 5.2.4. Hardware test (lab table)

2.4.5.1 Lab table programmable unit test to be transferred to WP7

Unit tests for the hardware tests will be defined the same way as it is described in Chapter [2.3.5.1. Lab table programmable unit test to be transferred to WP7](#)

3 Selection of Observables for the Main Use Cases

The main Use Cases in the ELECTRA project have been defined in Deliverable D3.1 [2], and are listed in the next table:

Table 5: Main Use Cases in ELECTRA

Control Type	UC abbreviation	Use Case
Balance Control	B1.IRPC	B1-Inertia Response Power Control
	B2.FCC	B2-Frequency Containment Control
	B3.BRC	B3-Balance Restoration Control
	B4.BSC	B4-Balance Steering Control
Voltage Control	T1.PVC	T1-Primary Voltage Control
	T2.PPVC	T2-Post-Primary Voltage Control

For each of the main Use Cases, the Control Triples selected for the Control Time Scales and Control Topology Levels are given in the next paragraphs. Next, a selection of not regularly used Control Triples is made for further definition of the observable algorithms, thereby forming Control Quadruples.

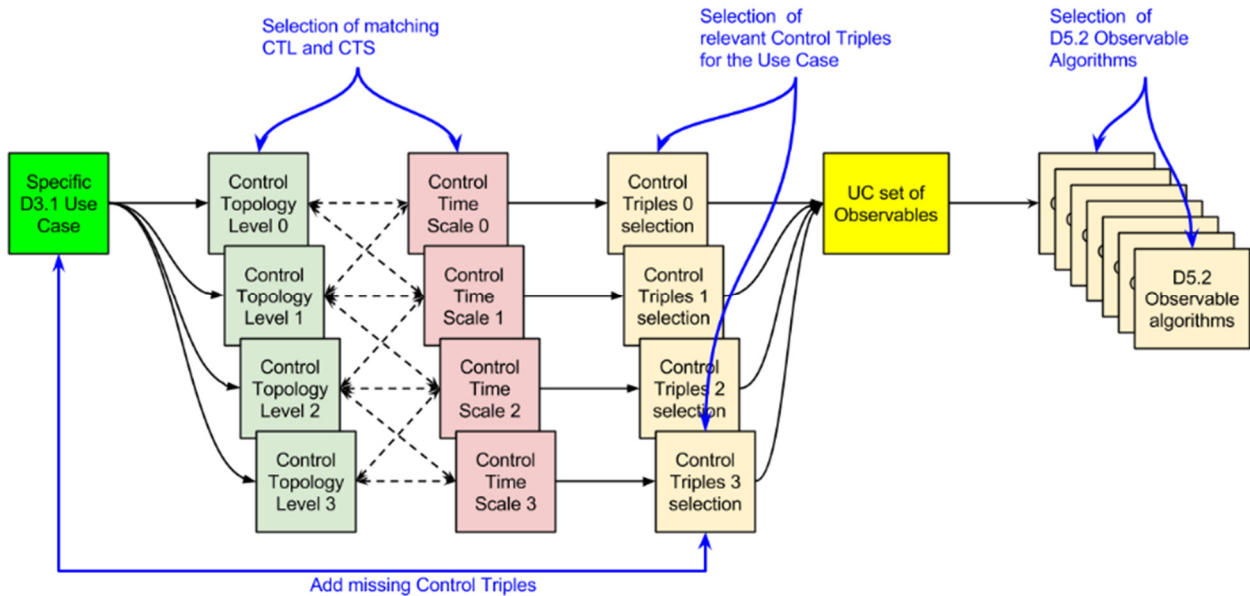

Figure 21: D5.2 Workflow - Observable Selection

3.1 Control Triples for Balance Control

The Control Triples serving the main Use Cases for Balance Control are summarised in the next table. For the actual status see the spreadsheet "Use Cases-Control Triples" Tab: "[WP5 Control Triples](#)" [18].

Table 6: Control Triples for Balance Control

Main Use Case	Control Aim	Observable	System Input Signal
B1- Inertia Response Power Control	Inertia Steering at Cell level [s]	Actual Cell Inertia time constant [s]	Deployment of a collection of slow starting Cell resources which exchange inertial response power [0/1] Deployment of inertial response power in a collection of converter interfaced resources [0/1]
	Inertia Steering at Synchronous Area level [s]	Actual Synchronous Area inertia [s]	Deployment of a collection of slow starting Cell resources which exchange inertial response power [0/1] Deployment of inertial response power in a collection of converter interfaced resources [0/1]
	Inertial Response Power Dynamic Control [s]	Inertial time constant of DER [s]	Inertial response power [W]
	Minimise stationary frequency fluctuations [Hz/s]	Actual frequency of node voltage [Hz]	Inertial response power [W]
	Secure transient frequency stability [Hz]	Actual frequency of node voltage [Hz]	Inertial response power [W]
B2- Frequency Containment Control	Minimise frequency deviations [Hz]	Frequency [Hz]	Active Power of aggregated resources [W]
	Regulation of Network Power Frequency Characteristic (λ_i) [W/Hz]	Actual Network Power Frequency Characteristic (λ_i) [W/Hz]	Deployment of Power-Frequency droop slope of aggregated resources [W/Hz]
		Cell Energy production in standard time interval [Ws]	Deployment of Power-Frequency droop slope of aggregated resources [W/Hz]
		Web-of-Cells Energy production in standard time interval [Ws]	Deployment of Power-Frequency droop slope of aggregated resources [W/Hz]
B3- Balance Restoration Control	Achieve a minimum of Reserve Capacity [W]	Availability of Flexible Resources [W]	Aggregated active power capacity [W]
	Bring frequency back to its set point [Hz]	Frequency [Hz]	Activation of Active Power of aggregated resources [W]
	Bring frequency back to	Frequency [Hz]	Activation of Active Power of

Main Use Case	Control Aim	Observable	System Input Signal
	its set point in a dynamically optimal way [Hz]		aggregated resources [W]
	Secure dynamically optimal power balance via aggregated resources [W]	Cell power balance [W]	Activation of Active Power of aggregated resources [W]
	Secure Power Balance by aggregated resources [W]	Cell power balance [W]	Activation of Active Power of aggregated resources [W]
B4- Balance Steering Control	Achieve a minimum of Reserve Capacity [W]	Availability of Flexible Resources [W]	Aggregated active power capacity [W]
	Maximise Operation & Maintenance efficiency of aggregated resources [1]	Operation & Maintenance efficiency of aggregated resources [1]	Deployment of Active Power of aggregated resources [W]
	Mitigate imminent Imbalances [W]	Active power of aggregated resources [W]	Deployment of Active Power of aggregated resources [W]
	Substitute aggregated reserves [W]	Active power of aggregated resources [W]	Deployment of Active Power of aggregated resources [W]

3.2 Control Triples for Voltage Control

The Control Triples serving the main Use Cases for Voltage Control are summarised in the next table. For the actual status see the spreadsheet "Use Cases-Control Triples" Tab: "[WP5 Control Triples](#)" [18]

Table 7: Control Triples for Voltage Control

Main Use Case	Control Aim	Observable	System Input Signal
T1- Primary Voltage Control	Minimise transient voltage deviations [V]	Actual node voltage [V]	Active power of Synchronous Generator [W] Active power of the controllable loads [W] complex power of aggregated resources (microgrids, VPPs...) [VA] Fast storage active and reactive power [VA] Reactive power of FACTS [VAr] Reactive power of synchronous generator/compensator [VAr]
		Current in DQO axis [A]	complex power of non-rotating generators [VA]
		Voltage in DQO axis [V]	complex power of non-rotating generators [VA]
T2- Post-Primary Voltage Control	Proactive over/undervoltages mitigation [V]	Collection (vector) of complex power	Active power set-points to DERs [W]

Main Use Case	Control Aim	Observable	System Input Signal
		[VA]	Optimal voltage set-points to DERs [V]
		Collection (vector) of voltage phasors [V,rad]	Active power set-points to DERs [W] Optimal voltage set-points to DERs [V]
	Restore voltage levels to pre-incident values while optimizing reactive power flows [V]	Collection (vector) of complex power [VA]	Active power set-points to DERs [W] Optimal voltage set-points to DERs [V]
		Collection (vector) of voltage phasors [V,rad]	Active power set-points to DERs [W] Optimal voltage set-points to DERs [V]

3.3 Resulting observables and their algorithms for Balance Control

The resulting Observables and their Algorithms serving the main Use Cases for Balance Control are summarised in the next table. For the actual status see the spreadsheet "Use Cases-Control Triples" Tab: "[WP5 Obs.Algorithms-HorVert](#)" [18] .

Table 8: Resulting observables and their algorithms for Balance Control

Main Use Case	Observable	Observable Algorithm
B1-Inertia Response Power Control	Actual Cell Inertia time constant [s]	Cell level determination of inertial time constant H and NPFC from exponential shape of power transient in tie-line.
	Actual frequency of node voltage [Hz]	1) Dual Second Order Generalised Integrator-Frequency Locked Loop 2) Digital Phase Locked Loop 3) Digital Fourier analysis 4) Three-phase space vector trajectory methods, including use of Clarke and Park transforms 5) Time domain numerical filter
		1) Dual Second Order Generalised Integrator-Frequency Locked Loop 2) Digital Phase Locked Loop 3) Digital Fourier analysis 4) Three-phase space vector trajectory methods, including use of Clarke and Park transforms 5) Time domain numerical filter
Actual Synchronous Area inertia [s]	Synchronous Area determination of inertial time constant H and NPFC from exponential shape of frequency transient.	

Main Use Case	Observable	Observable Algorithm
	Inertial time constant of DER [s]	Device level determination of actual response power from the fluctuations in device power caused by frequency changes.
B2-Frequency Containment Control	Actual Network Power Frequency Characteristic (λ_i) [W/Hz]	Cell determination of inertial time constant H and NPFC from exponential shape of power transient in tie-line.
	Cell Energy production in standard time interval [Ws]	Moving window integration of tie-line power flows (window time interval e.g. equal to market time interval)
	Frequency [Hz]	1) Zero crossing detection 2) Digital Phase Locked Loop
	Web-of-Cells Energy production in standard time interval [Ws]	Sum over all cells of Cell Energy production in standard time interval [Ws]
B3-Balance Restoration Control	Availability of Flexible Resources [W]	Power profile portfolio of aggregated resources
	Cell power balance [W]	Determine Cell power balance (e.g. Sum of measured tie-line power flows, or SOC deviation of local store.)
	Frequency [Hz]	1) Zero crossing detection 2) Digital Phase Locked Loop
B4-Balance Steering Control	Active power of aggregated resources [W]	Power profile of portfolio of aggregated resources
	Availability of Flexible Resources [W]	Power profile portfolio of aggregated resources
	Operation & Maintenance efficiency of aggregated resources [1]	Operation & Maintenance efficiency function of portfolio of aggregated resources

3.4 Resulting Observables and their algorithms for Voltage Control

The resulting Observables and their Algorithms serving the main Use Cases for Voltage Control are summarised in the next table. For the actual status see the spreadsheet "Use Cases-Control Triples" Tab: "[WP5 Obs.Algorithms-HorVert](#)" [18].

Table 9: Resulting Observables and their algorithms for Voltage Control

Main Use Case	Observable	Observable Algorithm
T1-Primary Voltage Control	Actual node voltage [V]	Moving window Root-Mean-Square (RMS) from sampled actual sine wave voltage.
		Park transformation
	Current in DQO axis [A]	Park transformation
	Voltage in DQO axis [V]	Park transformation
T2-Post-Primary Voltage Control	Collection (vector) of complex power [VA]	From the voltage and current waveform measurements: - Voltage phasor calculation (RMS, phase) - Complex power calculation (extraction of active and reactive power if needed)
	Collection (vector) of voltage phasors [V,rad]	From the voltage and current waveform measurements:

Main Use Case	Observable	Observable Algorithm
		- Voltage phasor calculation (RMS, phase) - Complex power calculation (extraction of active and reactive power if needed)
		From the voltage and current waveform measurements: - Voltage phasor calculation (RMS, phase) - Complex power calculation (extraction of active and reactive power if needed)

Observables needed for PPVC (vector of voltage phasors and vector of complex powers) are already calculated from measurements mainly by TSOs to run state estimation and OPF processes at transmission level. This practice will be extended in ELECTRA to the distribution level (cells).

3.5 Selection of Observables for further definition and testing

Now from the previous tables a selection of not regularly used Observables and Observable Algorithms is made. These observable algorithms are to be further defined and tested in Task T5.2.

Table 10: Selection of not regularly used Observables and Observable Algorithms

Main Use Case	Observable	Observable Algorithm
B1-Inertia Response Power Control	Actual Cell Inertia time constant [s]	Cell level determination of inertial time constant H and NPFC from exponential shape of power transient in tie-line.
	Actual frequency of node voltage [Hz]	1) Dual Second Order Generalised Integrator-Frequency Locked Loop 2) Digital Phase Locked Loop 3) Digital Fourier analysis 4) Three-phase space vector trajectory methods, including use of Clarke and Park transforms 5) Time domain numerical filter
	Actual Synchronous Area inertia [s]	Synchronous Area determination of inertial time constant H and NPFC from exponential shape of frequency transient.
	Inertial time constant of DER [s]	Device level determination of actual response power from the fluctuations in device power caused by frequency changes.
B2-Frequency Containment Control	Actual Network Power Frequency Characteristic (λ_i) [W/Hz]	Cell determination of inertial time constant H and NPFC from exponential shape of power transient in tie-line.
	Cell Energy production in standard time interval [Ws]	Moving window integration of tie-line power flows (window time interval e.g. equal to market time interval)
	Web-of-Cells Energy production in standard time interval [Ws]	Sum over all cells of Cell Energy production in standard time interval [Ws]
B3-Balance Restoration Control	Availability of Flexible Resources [W]	Power profile portfolio of aggregated resources
	Cell power balance [W]	Determine Cell power balance (e.g. Sum of measured tie-line power flows, or SOC deviation of

		local store.)
B4-Balance Steering Control	Active power of aggregated resources [W]	Power profile of portfolio of aggregated resources
	Availability of Flexible Resources [W]	Power profile portfolio of aggregated resources
	Operation & Maintenance efficiency of aggregated resources [1]	Operation & Maintenance efficiency function of portfolio of aggregated resources

4 Conclusions

The first part of T5.2 "Observables for Distributed Local Control Schemes" concentrated on several activities, which have been documented in the present report:

- Clarification of the scope of Local Control schemes
- More specific stepwise definition of the methodological approach for the whole Task
- Identification of control aims, based on a set of Use Cases (UCs)
- Identification of the needed Control Triples, by using and extending the Control Triples Survey from D5.1 [3]
- Determination methods for specific observables
- The Task continued working on the formal framework in WP5, which was initiated in the preceding T5.1.

The document outlines a methodology specifically created for developing and testing observables for the WoC concept. One of the most important lessons learned in this Task is that development of a radically new concept coined Web-of-Cells for control of the future power system with a high share of RES is a complicated process requiring rethinking of several well-established fundamental principles in the power system domain. In particular, conventional frequency and voltage controls have been reconsidered and the former has been replaced with a more general balance control concept, while the structure of the latter has been modified. These activities have required introduction of several new terms of definitions, which have been proposed in cooperation with WP6. Some of these have been further developed from the previous Tasks, such as Control Time Scales (CTS), while the others are new, such as Control Topology Levels (CTL).

Preparing to the succeeding part of the Task with implementations and testing, a specific part of work was dedicated to the further development of the Single Reference Power System started in T5.1. Among the major novelties are: a demonstration of the SRPS for a simple test network, a structured methodology incorporating the concept of Control Quadruples and Black Box Control Loop description into the Use Case method. Specific algorithms to be investigated for defining new observables have also been determined. In particular the established method for instantaneous reactive power looks promising for the definition of instantaneous frequency.

In a similar manner the concept of Control Triples from T5.1 has been further developed and specific control triples have been identified for the proposed control schemes. This has further materialised into specific observables and algorithms necessary for the definition of these.

The results so far also indicate that the WoC concept together with the above mentioned methodology built on top of the Use Case methodology allow for determining observables for an electric power system supporting future energy systems.

One of the main conclusions is that the conducted work supports the previously launched idea of Web-of-Cells concept, which appears to be viable. Today the Web-of-Cells has evolved from a vague idea in D3.1 into more detailed concept. This leads to WoC dedicated control schemes and priorities, which will allow for solving the local problems locally and thus increasing the overall robustness of power system with high share of RES. This will be more specifically studied and verified in the following implementation part of the Task.

5 References

- [1] [ELECTRA IRP](#) (ELECTRA IRP web site)
- [2] Caerts C. et al. ELECTRA Report D3.1 "*Specification of Smart Grids high level functional architecture for frequency and voltage control*" Version 2.1 April 2015
- [3] Morch A.Z. et al. ELECTRA Technical Report D5.1 "*Adaptive Assessment of Future Scenarios and Mapping of Observability Needs*" December 2014
- [4] Rodríguez, E. et al. ELECTRA Internal Report R3.1 "*Problem Description: specification of the requirements for the overall Smart Grid Voltage and Frequency Control*". July 2014
- [5] [The 2020 climate and energy package](#), European Commission
- [6] [Microgrid Definitions](#), U.S. Department of Energy Microgrid Exchange Group and CIGRÉ C6.22 Working Group
- [7] "[Wind turbines reached record level in 2014](#)", Energinet.dk
- [8] Calin M. et al. ELECTRA Report D2.1 "*European smart grids research infrastructure database*", Version 2.0, October 2014
- [9] Visscher K. et al. ELECTRA Technical Report D6.1 "*Functional specification of the control functions for the control of flexibility across the different control boundaries*", Intermediate version, October 2015
- [10] [Observables Inventory Survey Webinar](#), ELECTRA IRP, July 2014.
- [11] Continental Europe Operation Handbook, ENTSO-E, 2004
- [12] B.M. Weedy, et al., "Electric Power Systems-Fifth Edition", Wiley, 2012
- [13] M. Jonsson, "*Protection Strategies to Mitigate Major Power System Breakdowns*", PhD Thesis, Sweden, 2003
- [14] A. Vassilakis, P. Kotsampopoulos, N. Hatziaargyriou, V. Karapanos, "*A Battery Energy Storage Based Virtual Synchronous Generator*", 2013 IREP Symposium, August 25-30, 2013, Rethymnon, Greece
- [15] Pieter Tielens, Dirk Van Hertem, "*Grid Inertia and Frequency Control in Power Systems with High Penetration of Renewables*", KU Leuven: Leuven, Belgium, 2012
- [16] Mohammad Seyedi, Math Bollen, "*The utilization of synthetic inertia from wind farms and its impact on existing speed governors and system performance*", Part 2 Report of Vindforsk Project V-369, January 2013
- [17] Akagi, H.; Kanazawa; Yoshihira; Nabae, A., "*Instantaneous Reactive Power Compensators Comprising Switching Devices without Energy Storage Components*", [Industry Applications, IEEE Transactions on](#) (Volume:IA-20 , Issue: 3), DOI: [10.1109/TIA.1984.4504460](#)
- [18] [Online spreadsheet 20150322-Use Cases-Control Triples](#), ELECTRA IRP, October 2015.
- [19] SVC. Static Var Compensator. An insurance for improved grid system stability and reliability. ABB Corpo.
- [20] [EU Energy Roadmap 2050](#)

6 Disclaimer

The ELECTRA project is co-funded by the European Commission under the 7th Framework Programme 2013.

The sole responsibility for the content of this publication lies with the authors. It does not necessarily reflect the opinion of the European Commission.

The European Commission is not responsible for any use that may be made of the information contained therein.

Annex: Summary of SRPS candidates

Please find this Annex at the next link:

[20151012-ELECTRA-D5.2-Annex: Summary of SRPS candidates](#)

Annex: General Measurements Chain for the currents and voltages by means of Phasor Measurements Units

Please find this Annex at the next link:

[20151012-ELECTRA-D5.2-Annex: General Measurements Chain for currents and voltages by means of Phasor Measurements Units](#)